

# PCD3.W210

Analog input module, 8 channel, 10 bit,  
0...20 mA (4...20 mA via software)

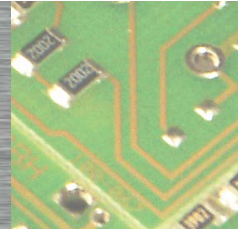

## Description

Fast, analog 8 channel input module with 0...20 mA (4...20 mA via software) and 10 bit resolution per channel. With its short conversion time of <math>< 50 \mu\text{s}</math>, this module is universally suitable for recording analogue signals.

## Technical specifications

Number of inputs (channels)	8
Signal range	0...20 mA (4...20 mA via Software)
Resolution (representation)	10 bit (0 ... 1023)
Galvanic separation	no
Measuring principle	non-differential, single-ended
Input resistance	125 $\Omega$ / 0.1 %
Accuracy (of measured value)	$\pm 3$ LSB
Repeating accuracy (under same conditions)	within 1 LSB
Temperature error (0 ... +55 °C)	$\pm 0.3$ % ( $\pm 3$ LSB)
Conversion time A/D	$\leq 50 \mu\text{s}$
Overcurrent protection	$\pm 40$ mA
Burst protection (IEC1000-4-4)	$\pm 1$ kV, with unshielded cables $\pm 2$ kV, with shielded cables
Time constant of input filter	typically 1 ms
Internal current consumption (from +5 V bus)	8 mA
Internal current consumption (from V+ bus)	5 mA
External current consumption	0 mA
Terminals	Pluggable 10-pole spring terminal block for $\varnothing$ up to 2.5 mm <sup>2</sup> , plug type A



PCD3.W210

## Indicators and connections

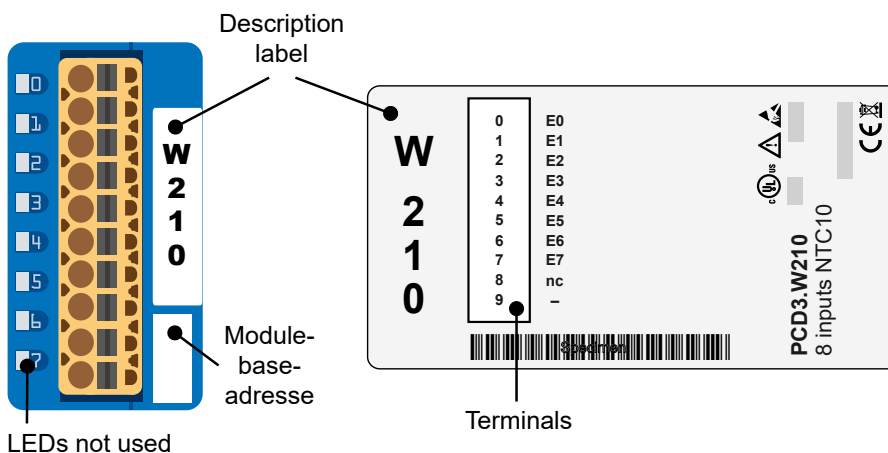

**Block diagram**

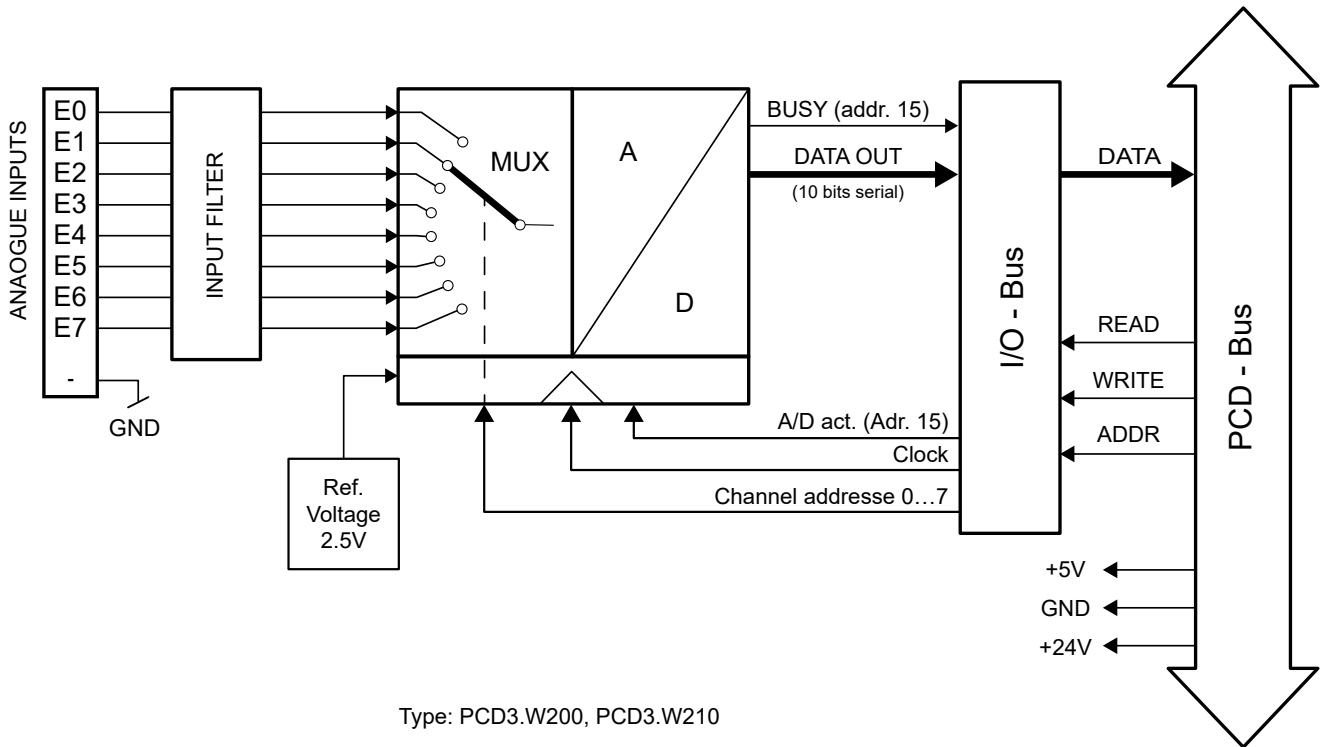

Two-wire transducers (0...20 mA and 4...20 mA transmitters) need a 24 VDC supply in the measuring trunk.

## Connection concept for two-wire transmitter

The input signals are connected directly to the 10-pole terminal block (E0 ... E7 and COM). To minimize the amount of interference coupled into the module via the transmission lines, connection should be made according to the principle explained below.

### Connection for 0...20 mA two-wire transmitter

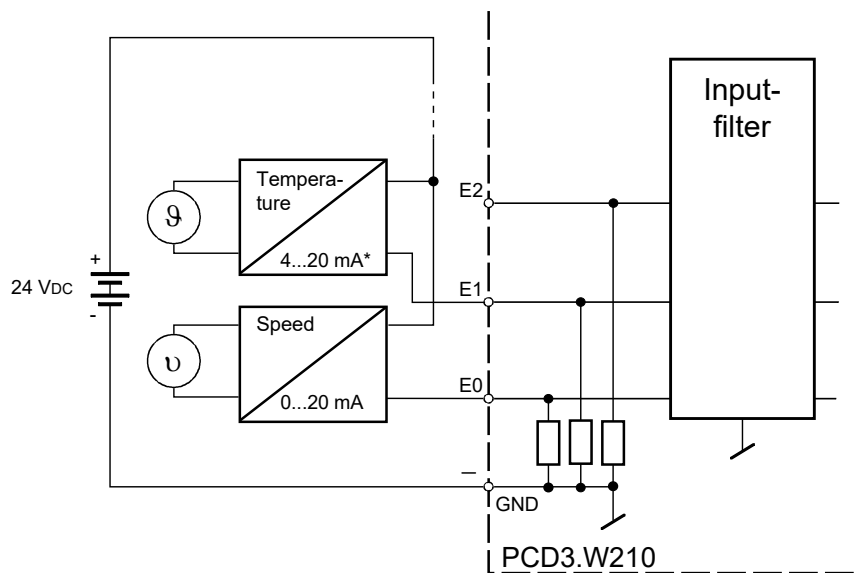

\*4...20 mA via userprogramm

	<p>The reference potentials of signal sources should be wired to a common GND connection (“-” and “COM” terminals). To obtain optimum measurement results, any connection to an earthing bar should be avoided.</p>
	<p>If shielded cables are used, the shielding should be connected to an earthing rail.</p>
	<p>Input signals with incorrect polarity significantly distort the measurements on the other channels.</p>



I/O modules and I/O terminal blocks may only be plugged in and removed when the Control Edge PCD and the external +24 V are disconnected from the power supply.



PCD3.W210



4 405 4954 0

**Ordering information**

Type	Short description	Description	Weight
PCD3.W210	8 analogue inputs 0...20 mA, 10 bit	Analogue input module, 8 inputs (channels), resolution 10 bit, signal range 0...20 mA (4...20 mA via software), the channels themselves not separated, connection with pluggable spring terminals, plug-in type A ((4 405 4954 0) included	80 g

**Ordering information equipment**

Type	Short description	Description	Weight
4 405 4954 0	Plug-in, type A	Plug-in I/O spring terminal block, 10-pole up to 2.5 mm <sup>2</sup> , labelled 0...9	15 g

**ATTENTION**

These devices must only be installed by a professional electrician, otherwise there is the risk of fire or the risk of an electric shock.

**WARNING**

Product is not intended to be used in safety critical applications, using it in safety critical applications is unsafe.

**WARNING - SAFETY**

The unit is not suitable for the explosion-proof areas and the areas of use excluded in EN61010 Part 1.

**WARNING - SAFETY**

Check compliance with nominal voltage before commissioning the device (see type label). Check that connection cables are free from damage and that, when wiring up the device, they are not connected to voltage. Do not use a damaged device !

**NOTE**

In order to avoid moisture in the device due to condensate build-up, acclimatise the device at room temperature for about half an hour before connecting.

**CLEANING**

The device can be cleaned in dead state with a dry cloth or cloth soaked in soap solution. Do not use caustic or solvent-containing substances for cleaning.

**MAINTENANCE**

These devices are maintenance-free.  
If damaged during, no repairs should be undertaken by the user.



Observe this instructions (data sheet) and keep them in a safe place.  
Pass on the instructions (data sheet) to any future user.

**WEEE Directive 2012/19/EC Waste Electrical and Electronic Equipment directive**

The product should not be disposed of with other household waste. Check for the nearest authorized collection centers or authorized recyclers. The correct disposal of end-of-life equipment will help prevent potential negative consequences for the environment and human health.



EAC Mark of Conformity for Machinery Exports to Russia, Kazakhstan or Belarus.

## Sales and Service

For application assistance, current specifications, pricing, or name of the nearest Authorized Distributor, contact one of the offices below.

### ASIA PACIFIC

Honeywell Process Solutions,  
(TAC) [hfs-tac-support@honeywell.com](mailto:hfs-tac-support@honeywell.com)

#### Australia

Honeywell Limited  
Phone: +(61) 7-3846 1255  
FAX: +(61) 7-3840 6481  
Toll Free 1300-36-39-36  
Toll Free Fax:  
1300-36-04-70

#### China – PRC - Shanghai

Honeywell China Inc.  
Phone: (86-21) 5257-4568  
Fax: (86-21) 6237-2826

#### Singapore

Honeywell Pte Ltd.  
Phone: +(65) 6580 3278  
Fax: +(65) 6445-3033

#### South Korea

Honeywell Korea Co Ltd  
Phone: +(822) 799 6114  
Fax: +(822) 792 9015

### EMEA

Honeywell Process Solutions,  
Phone: +80012026455 or  
+44 (0)1344 656000

Email: (Sales)  
[FP-Sales-Apps@Honeywell.com](mailto:FP-Sales-Apps@Honeywell.com)  
or  
(TAC) [hfs-tac-support@honeywell.com](mailto:hfs-tac-support@honeywell.com)

### AMERICA'S

Honeywell Process Solutions,  
Phone: (TAC) 1-800-423-9883 or  
215/641-3610  
(Sales) 1-800-343-0228

Email: (Sales)  
[FP-Sales-Apps@Honeywell.com](mailto:FP-Sales-Apps@Honeywell.com)  
or  
(TAC) [hfs-tac-support@honeywell.com](mailto:hfs-tac-support@honeywell.com)

## WARRANTY/REMEDY

Honeywell warrants goods of its manufacture as being free of defective materials and faulty workmanship. Contact your local sales office for warranty information. If warranted goods are returned to Honeywell during the period of coverage, Honeywell will repair or replace without charge those items it finds defective. The foregoing is Buyer's sole remedy and is **in lieu of all other warranties, expressed or implied, including those of merchantability and fitness for a particular purpose.** Specifications may change without notice. The information we supply is believed to be accurate and reliable as of this printing. However, we assume no responsibility for its use.

While we provide application assistance personally, through our literature and the Honeywell web site, it is up to the customer to determine the suitability of the product in the application.

*Specifications are subject to change without notice.*

---

## For more information

Learn more about ControlEdge PCD, visit our website [www.honeywellprocess.com/ControlEdgePCD](http://www.honeywellprocess.com/ControlEdgePCD) or contact your Honeywell account manager.

## Honeywell Process Solutions

2101 CityWest Blvd, Houston TX 77042  
Honeywell House, Skimped Hill Lane

Bracknell, Berkshire, England RG12 1EB UK ©2020 Honeywell International Inc.  
Building #1, 555 Huanke Road,

Zhangjiang Hi-Tech Industrial Park,  
Pudong New Area, Shanghai 201203

Document No.: 51-52-03-79  
Rev.3.1  
June 2020

