

# PCD3.M6893

## IEC-Controller

### Cyber Secure, IEC 61131-3

## General

The powerful PCD3.M6893 is a cyber secure PLC and programmable in accordance with IEC 61131-3.

The high-level language for structured text (ST) according to IEC 61131-3, has a strong syntax and supports object-oriented methods. The most recent cyber security level (ANSI ISA62443 – SL3) enables the use in mission critical and IoT/Cloud applications. This modular PLC offers integrated USB, Ethernet, RS-485 and CAN bus interfaces. It is compatible with the modular and robust I/O system of the SBC PCD3 family.

With the PCD3.M6893 controllers, redundant automation solutions can be achieved. This helps to ensure uninterrupted operation of systems and processes.

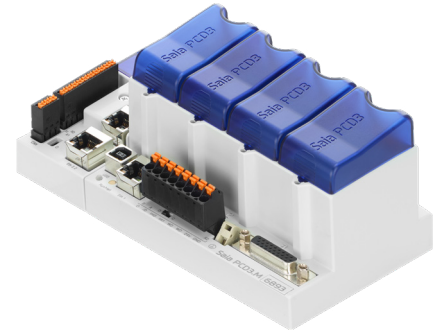

PCD3.M6893

## Features

### Maximum peripheral connections

- Ethernet and USB-port onboard
- One serial interface RS-485 onboard
- One serial interface RS-485 pluggable on Slot A
- Up to 1023 central inputs/outputs with expansion module holder PCD3.Cx00 (up to 64 modules with max. 16 contact points each). The first module holder must always be a PCD3.C200
- Additional remote inputs/outputs via Modbus IP with PCD controller and I/O modules

### PCD3 I/O modules in cassette form

**More than 40 I/O modules available with different functionalities, see order details**

- Status of digital signals indicated via LEDs
- Configurable process image via System Configuration software

### Efficient programming tools

Learn more at [www.sbc-support.com](http://www.sbc-support.com)

- IEC programming software QronoX from SBC with integrated System- and Account Management Configuration and comprehensive application components make programming convenient and efficient
- A coordinating combination of operating system and programming tool achieves maximum speed, reliability and functionality

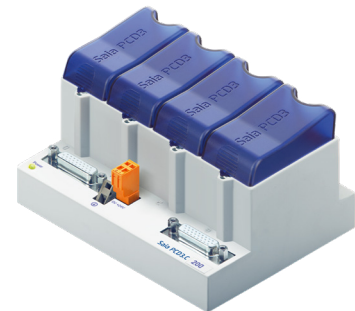

PCD3.C200

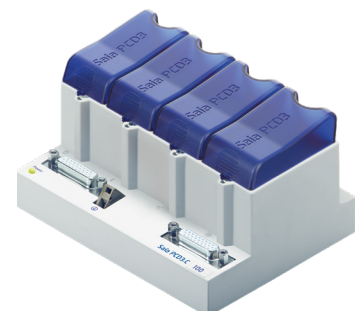

PCD3.C100

## General technical data / Operating conditions

### Power supply

Supply voltage (according EN/IEC 61 131-2)	24 VDC –20 / +25%, incl. 5% ripples
Current / Power consumption (Without the burden of the I/Os)	typ. 175 mA / 4.2 W, max. 500 mA / 18 W
Load-carrying ability 5 V / 24 V internal	max. 600 mA / 100 mA
Short voltage interruption (according EN/IEC 61 131-2)	≤ 10 ms with interval ≥ 1 s

### Electrical data

2 Interrupt inputs	24 VDC up to 100 Hz
Watchdog relay closing contact	48 VAC or VDC <sup>1)</sup> , 1 A
Real-time clock (RTC)	Yes, maximum deviation of 1 minute per month at 25°C
Supercap to support the real-time clock	10 days <sup>2)</sup>

### Environmental influences

Storage temperature (according EN/IEC 61 131-2)	–25...+70 °C
Ambient temperature operating (according EN/IEC 61 131-2)	0...+55 °C <sup>3)</sup> or 0...+40 °C (depending on mounting situation)
Relative air humidity (according EN/IEC 61 131-2)	10...95 % r.h., non condensing

### Mechanical data

Type of mounting	Top-hat rail according to DIN EN 60715 TH35 (formerly DIN EN 50022) (1 × 35 mm)
Protection level	IP 20
Flame resistance	UL 94 V0
Vibration (according EN/IEC 61 131-2)	3.5 mm / 1.0 g sinusoidally
Shock (according EN/IEC 61 131-2)	15 g / 11 ms sinus half wave

- 1) mount a free-wheeling diode over the load when switching DC tension
- 2) to extend this period, a PCD3.R010 module may be plugged into one of the four IO slots of the CPU.
- 3) when assembling on vertical surface, all other mounting methods 0...40 °C

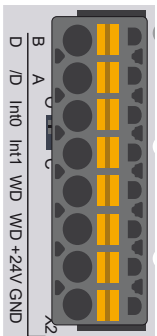

Pin	Signal	Explanation
1	D	Port #2 RS-485 up to 115.2 kbit/s usable as free user interface
2	/D	
3	Int0	2 interrupt inputs 24 VDC
4	Int1	
5	WD	Watchdog
6	WD	
7	+24V	Voltage supply
8	GND	

### RS-485 terminator switch for Port #2

Switch	Switch position	Designation	Explanation
	left	o	without termination resistors
	right	c	with termination resistors

## Communication interfaces

Interface	Marking	Port #	Description
Ethernet 1	Eth 1		Single Port, 10/100 MBit/s
Ethernet 2	Eth 2.1 Eth 2.2		Two ports switched 10/100 MBit/s
USB Device	USB		One port with Remote NDIS driver, a virtual IP port for Programming, Commissioning, Service and Web access
USB Host	Port 3	3	One port for External Hardware Key/Dongle for software licensing
RS-485	X2 D + /D	2	One port, not isolated for general purpose, up to 115.2 kbit/s, on board bus termination switch
Slot A	Slot A X0	1	One socket for PCD7.F110S or PCD7.F150S communication interface modules
Micro SD	micro SD		One Slot for optional Micro SD card PCD7.R-MSD1024 *
CAN	X1 CAN		One port, galvanic isolated, hardware prepared for CAN 20a and 20b, up to 1 MBit/s, on board bus termination switch (120 Ω)

\* The optional file system is required for application programs handling user defined data

## Connections X0 and X1

### X0 – Communication interfaces: position Slot A

Pin	PCD7.F110S	PCD7.F150S
	RS-485	RS-485*
0	PGND	PGND
1	Rx-Rx	Rx-Rx
2	/Rx-/Tx	/Rx-/Tx
3		
4		
5	PGND	PGND
6		
7		
8		SGND
9		

\* galvanic isolation

### X1 – CAN bus terminal

Pin	Signal
H	CAN_H
L	CAN_L
⊥	CAN_GND

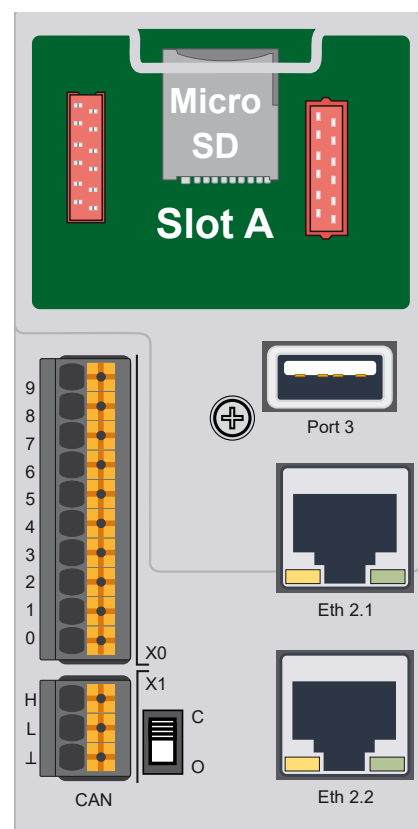

## Protocol overview

Protocol	Interfaces	Application note
<b>Engineering tool</b>	Ethernet 1, 2, USB Device	Programming tool communication encrypted. Defaults: Port 11740 USB via RNDIS Driver, see factory set up
<b>Modbus TCP</b>	Ethernet 1, 2	Modbus TCP Server and Client configurable via Software Configurator. A maximum of 32 slaves can be attached to a master. Modbus TCP slave can also take over gateway functions to Modbus RTU/ASCII
<b>Modbus RTU/ASCII</b>	RS-485 Port 2, Slot A* Port 0	Modbus RTU/ASCII Serial Master or Serial Slave configurable via Software Configurator
<b>Profinet</b>	Ethernet 1, 2	Station configurable via Software Configurator. Minimum Communication Cycle time 2 ms
<b>OPC-UA</b>	Ethernet 1, 2	Address space configurable according PLC-Open for IEC 61131-3 controllers. Encryption and Authentication configurable, default enabled.
<b>User defined</b>	All	User defined protocols can be implemented via the application program based on system low level drivers like SysCom, ...
<b>CAN</b>	CAN	Hardware prepared for CAN 20a, 20b. CAN raw, J1939 and CAN open. Not supported by standard product, available on demand.
<b>M-Bus</b>	plug-in PCD3.F27X modules	Master-Slave communication on a 2 -wire bus. Star, Line or Tree topology as per standard M-Bus specifications
<b>IEC-60870-5-104</b>	Ethernet 1,2	IEC 60870-5-104 Sever functionality on QronoX, Requires license from Codesys store
<b>IEEE 802.1x</b>	Ethernet 1,2	IEEE standard for Port-based network access control. User needs to enable the feature on ethernet ports (disabled by default)

\* equipped with a PCD7.F150S

### OPC UA : OPC UA Server, data access (as of FW 5.14.8) \*

Parameter	Description
Security Policies	None, Basic256Sha256, Aes128Sha256RsaOaep, Aes256Sha256RsaPss
Message security mode	None, Sign, Sign&Encrypt
User authentication	Anonymous, Username + password
Number of Sessions (maximum)	1 to 50 (configurable)
Number of Subscriptions per Session (maximum)	20
Sampling Interval	200ms-60000ms (configurable)
Publishing Interval (minimum)	200ms
Number of Monitored Items (recommended max.)	1000 @1000ms

\* The above recommended limits are based on the following system operating conditions:

- Sampling Interval (for all items): 1000ms
- Publish Interval: 1000ms
- 1 Active subscriptions
- 1 Active session
- Exclusively OPC UA communication (no other communication over TCP/IP is executed, for example Modbus, Web Server)
- PLC Task cycle time: 200ms
- PLC Task effective execution time: less than 10ms
- No Freewheeling task
- Data type of the variables: DINT (UInt32)

**Limitations for IEC 60870-5-104\***

Parameter	Description
IEC 60870-5-104 Server	2
Station address (ASDU)	4
Master Connections	4
All-objects	2000

\* As per Codesys Release version 1.0.6.0

**Application notes****PLC program**

- Program size: 10 MBytes
- Program Memory: 50 MBytes
- Program Memory, persistent none volatile: 128 KBytes

**PCD3 I/O Process Image**

I/O update via process image within one program,

- Bus cycle task configurable, min. 2 ms
- Digital Inputs / Outputs: Update cycle 2 ms
- Analogue Input / Outputs:  
Update cycle per module (8 channels), 50...100 ms  
multiple analogue module in parallel

**Factory set up**

- USB Device RNDIS driver enabled, Firewall open for engineering tool IP address 169.254.1.1, Subnet 255.254.0.0
- Ethernet 1 Disabled
- Ethernet 2 Disabled
- Serial Com Port 2 Disabled
- Serial Com. Port on slot A Disabled

**Dimension Drawing**  
PCD3.M6893

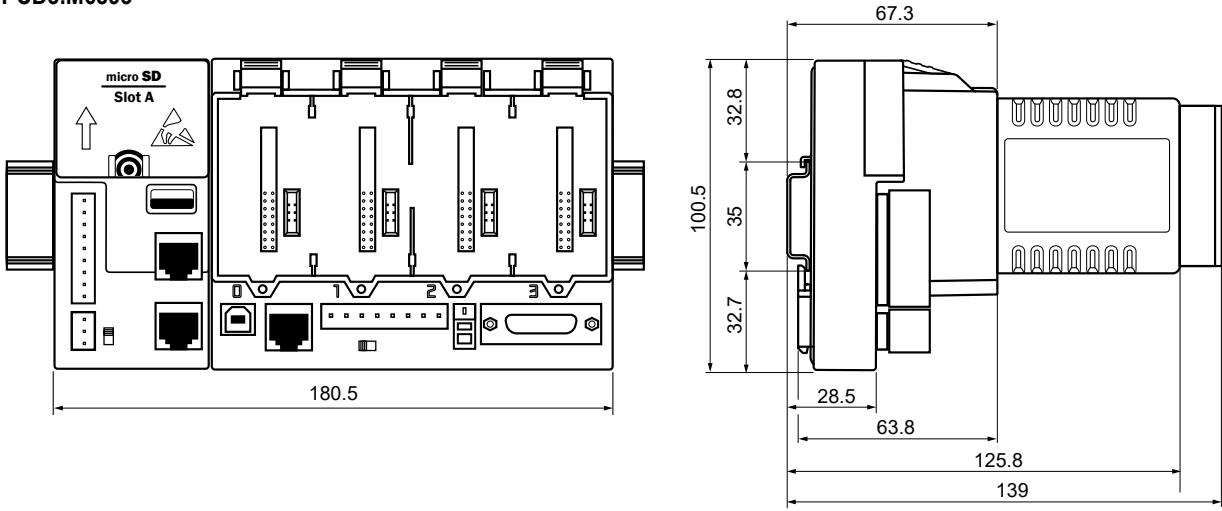

**PCD3.C200**

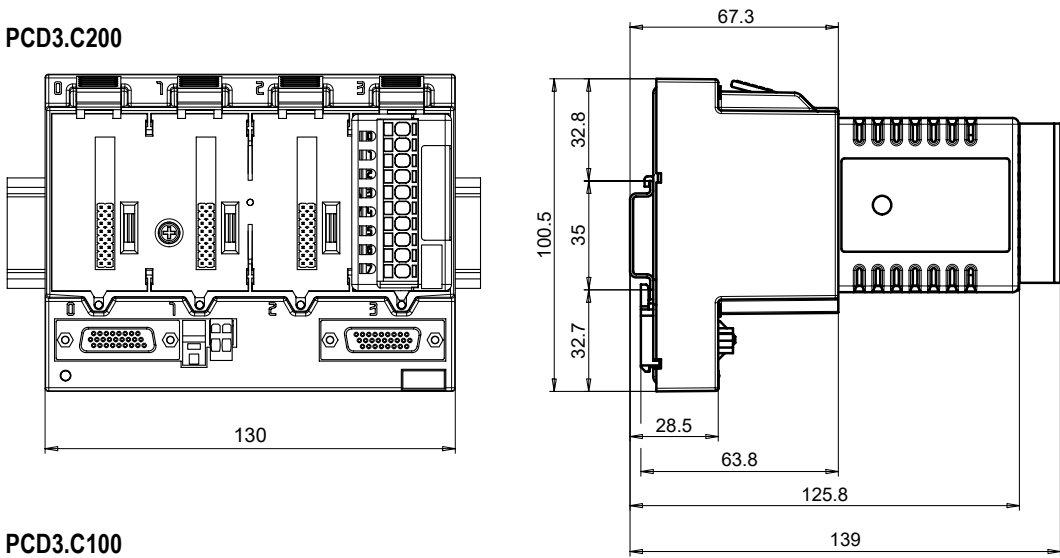

**PCD3.C100**

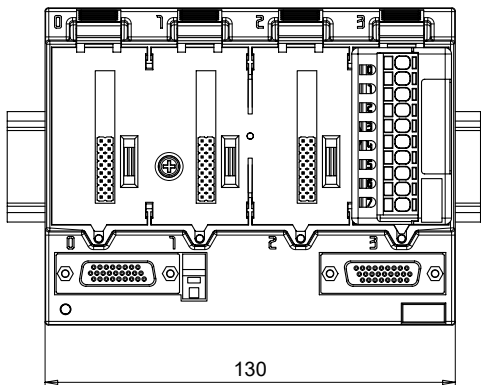

Dimensions like PCD3.C200  
(see drawing above)

**Planning data**

- ▶ Step files (3D)
- ▶ BIM objects

The data can be downloaded be downloaded with the following link:

<https://sbc-support.com/en/services/bim-building-information-model/>

## Connecting plugs/terminals

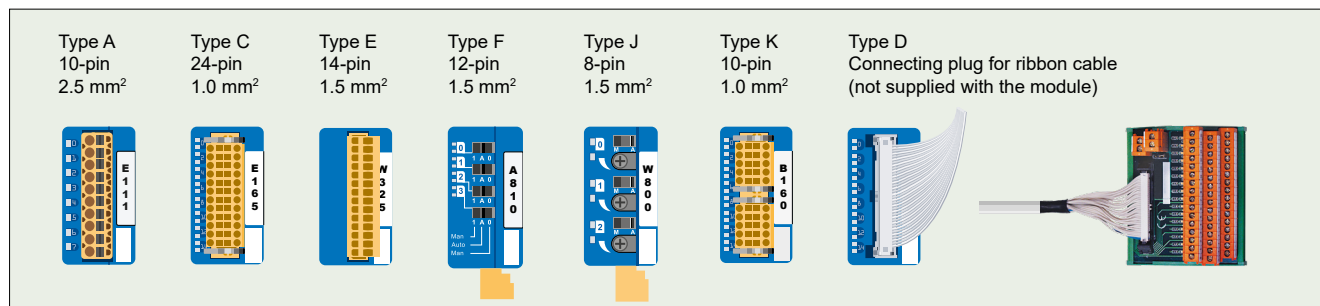

▲ Spare terminals, ribbon connectors with system cables and separate terminals are ordered as accessories.

## Compatibility note



**Minimum required firmware package for PCD3.A810 and PCD3.W800 modules: 4.x.x**  
**Minimum required firmware package for all remaining I / O modules: 3.0.0**

## Digital input modules

Type	Number of inputs	Input		Electrical isolation	Internal current draw		I/O connector type <sup>3)</sup>
		voltage	delay		5 V-Bus <sup>1)</sup>	V-Bus <sup>2)</sup>	
PCD3.E110	8	15...30 VDC	8 ms	---	24 mA	---	A
PCD3.E111	8	15...30 VDC	0.2 ms	---	24 mA	---	A
PCD3.E160	16	15...30 VDC	8 ms	---	10 mA	---	D
PCD3.E161	16	15...30 VDC	0.2 ms	---	10 mA	---	D
PCD3.E165	16	15...30 VDC	8 ms	---	10 mA	---	C
PCD3.E166	16	15...30 VDC	0.2 ms	---	10 mA	---	C
PCD3.E500 **	6	80...250 VAC *	20 ms	●	1 mA	---	A
PCD3.E610	8	15...30 VDC	10 ms	●	24 mA	---	A
PCD3.E613 **	8	30...60 VDC	9 ms	●	24 mA	---	A

\* These ratings are not UL-listed

\*\* Not recommended for new projects

## Digital output modules

Type	Number of outputs	Output switching capacity		Electrical isolation	Internal current draw		I/O connector type <sup>3)</sup>
		DC	AC		5 V-Bus <sup>1)</sup>	V-Bus <sup>2)</sup>	
PCD3.A200	4, relay (make) *	2 A/50 VDC **	2 A/250 VAC	●	15 mA	---	A
PCD3.A210 ****	4, relay (break) *	2 A/50 VDC **	2 A/250 VAC	●	15 mA	---	A
PCD3.A220	6, relay (make)	2 A/50 VDC **	2 A/250 VAC	●	20 mA	---	A
PCD3.A251	8, relay (6 changeover + 2 make)	2 A/50 VDC ***	2 A/48 VAC	●	25 mA	---	C
PCD3.A300	6, transistor	2 A/10...32 VDC	---	---	20 mA	---	A
PCD3.A400	8, transistor	0.5 A/5...32 VDC	---	---	25 mA	---	A
PCD3.A410	8, transistor	0.5 A/5...32 VDC	---	●	24 mA	---	A
PCD3.A460	16, transistor	0.5 A/10...32 VDC	---	---	10 mA	---	D
PCD3.A465	16, transistor	0.5 A/10...32 VDC	---	---	10 mA	---	C
PCD3.A810 Manual operation	4, relay (2 changeover + 2 make)	2 A/50 VDC 2 A/50 VDC	5 A/250 VAC 6 A/250 VAC	● ●	55 mA	---	F

\* With contact protection

\*\* For UL61010 compliant operation the following switching capacity applies: 2 A/35 VDC

\*\*\* For UL61010 compliant operation the following switching capacity applies: 2 A/30 VDC

\*\*\*\* Not recommended for new projects

### Analogue input modules

Type	Number of channels	Signal ranges/description	Resolution	Electrical isolation	Internal current draw		I/O connector type <sup>3)</sup>
					5 V-Bus <sup>1)</sup>	+ V-Bus <sup>2)</sup>	
PCD3.W200	8 In	0...+10 V	10 Bit	---	8 mA	5 mA	A
PCD3.W210	8 In	0...20 mA <sup>4)</sup>	10 Bit	---	8 mA	5 mA	A
PCD3.W220	8 In	Pt1000: -50 °C...400 °C Ni1000: -50 °C...+200 °C	10 Bit	---	8 mA	16 mA	A
PCD3.W300	8 In	0...+10 V	12 Bit	---	8 mA	5 mA	A
PCD3.W310	8 In	0...20 mA <sup>4)</sup>	12 Bit	---	8 mA	5 mA	A
PCD3.W340	8 In	0...+10 V/0...20 mA <sup>4)</sup> Pt1000: -50 °C...400 °C Ni1000: -50 °C...+200 °C	12 Bit	---	8 mA	20 mA	A
PCD3.W350	8 In	Pt100: -50 °C...+600 °C Ni100: -50 °C...+250 °C	12 Bit	---	8 mA	30 mA	A
PCD3.W360	8 In	Pt1000: -50 °C...+150 °C	12 Bit	---	8 mA	20 mA	A
PCD3.W380	8 In	-10 V...+10 V, -20 mA...+20 mA, Pt/Ni1000, Ni1000 L&S, NTC10k/NTC20k (configuration using software)	13 Bit	---	25 mA	25 mA	2× K
PCD3.W305	7 In	0...+10 V	12 Bit	●	60 mA	0 mA	E
PCD3.W315	7 In	0...20 mA <sup>4)</sup>	12 Bit	●	60 mA	0 mA	E
PCD3.W325	7 In	-10 V...+10 V	12 Bit	●	60 mA	0 mA	E
PCD3.W745	4 In	Temperature module for TC type J, K and 4-wire Pt/Ni 100/1000	16 Bit	●	200 mA	0 mA	<sup>5)</sup>

### Analogue output modules

Type	Number of channels	Signal ranges/description	Resolution	Electrical isolation	Internal current draw		I/O connector type <sup>3)</sup>
					5 V-Bus <sup>1)</sup>	+ V-Bus <sup>2)</sup>	
PCD3.W400	4 Out	0...+10 V	8 Bit	---	1 mA	30 mA	A
PCD3.W410	4 Out	0...+10 V/0...20 mA/4...20 mA jumper-selectable	8 Bit	---	1 mA	30 mA	A
PCD3.W600	4 Out	0...+10 V	12 Bit	---	4 mA	20 mA	A
PCD3.W610	4 Out	0...+10 V/-10 V...+10 V/ 0...20 mA/4...20 mA jumper-selectable	12 Bit	---	110 mA	0 mA	A
PCD3.W605	6 Out	0...+10 V	10 Bit	●	110 mA	0 mA	E
PCD3.W615	4 Out	0...20 mA/4...20 mA parameters can be set	10 Bit	●	55 mA	0 mA	E
PCD3.W625	6 Out	-10 V...+10 V	10 Bit	●	110 mA	0 mA	E
PCD3.W800	4 Out, 3 of which are manually operated	0...+10 V, short circuit-protected	10 Bit	---	55 mA	35 mA <sup>6)</sup>	J

### Overview of the internal bus capacity of the module holders

	PCD3.M6893	PCD3.C200
1) Internal 5V	600 mA	1500 mA
2) Internal +V (24 V)	100 mA	200 mA

The electrical requirement of the internal +5V and +V bus for the I/O modules can be calculated in the CronoX I/O-Builder.

- 3) Plug-in I/O terminal blocks are included with I/O modules.  
Spare terminals, ribbon connectors with system cables and separate terminals are ordered as accessories.
- 4) 4 ... 20 mA via user program.
- 5) With soldered spring terminal block.
- 6) At 100% output value and 3 kΩ load.

### Manual control modules

PCD3.A810  
Relay outputs,  
2 changeover and 2 make

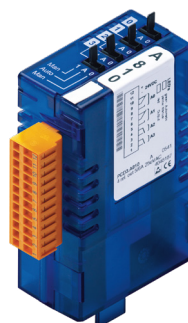

PCD3.W800  
4 analogue outputs  
(3 of these operable)





### Information for project planning with PCD3 module holders

The internal load current taken by the I/O modules from the +5V and +V (24V) supply must not exceed the maximum supply current specified for the CPUs, RIOs or PCD3.C200 module holders.

#### Example calculation for the current consumption of the internal +5V and +V (24V) bus of the I/O modules

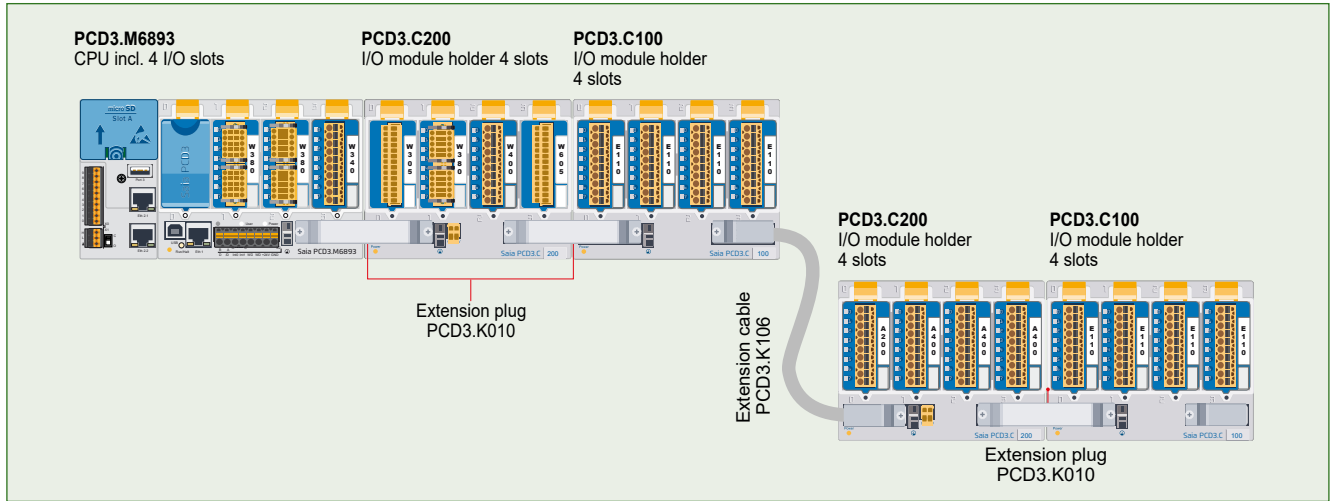

#### Consumption M6893 + C200 + C100

Module	Internal 5V	Internal +V (24V)
Not used		
W380	25 mA	25 mA
W380	25 mA	25 mA
W340	8 mA	20 mA
<b>Total M6893</b>	<b>58 mA</b>	<b>70 mA</b>
W340	8 mA	20 mA
W340	8 mA	20 mA
W610	110 mA	0 mA
E160	10 mA	
<b>Total C200</b>	<b>136 mA</b>	<b>40 mA</b>
E160	10 mA	
E160	10 mA	
E160	10 mA	
<b>Total C100</b>	<b>40 mA</b>	<b>0</b>
<b>Total C200</b>	<b>176 mA</b>	<b>40 mA</b>

#### Consumption C200 + C100

Module	Internal 5V	Internal +V (24V)
A200	15 mA	
A810	40 mA	
A810	40 mA	
A860	18 mA	
<b>Total C200</b>	<b>113 mA</b>	
A460	10 mA	
A460	10 mA	
A460	10 mA	
W380	25 mA	25 mA
<b>Total C100</b>	<b>55 mA</b>	<b>25 mA</b>
<b>Total C200</b>	<b>168 mA</b>	<b>25 mA</b>

Capacity	PCD3.M6893	PCD3.C200
Internal 5V	600 mA	1500 mA
Internal +V (24V)	100 mA	200 mA

The calculation example shows that internal capacity is maintained in the CPU basic module PCD3.M6893 and the holder module PCD3.C200. The CPU basic module has a sufficient reserve to receive an additional communication module in the empty slot 0. The holder module PCD3.C200 also has sufficient reserves to connect an additional PCD3.C100 holder module. The power consumption of the internal +5V and +V (24 V) bus for the I/O modules is automatically calculated in the CronoX I/O-Calculator Excel-sheet.

## Insertion of I/O modules

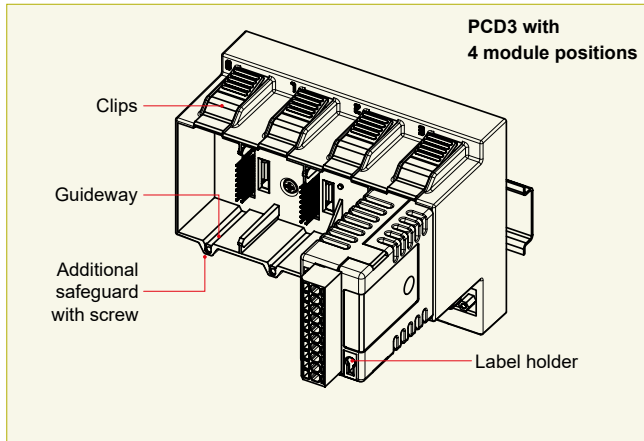

▲ Simple exchange of I/O modules

## Over 40 modules available with different functionalities

### Types

- ▶ **PCD3.Axxx** Digital output modules
- ▶ **PCD3.Exxx** Digital input modules
- ▶ **PCD3.Wxxx** Analogue input/output modules

**!** The PCD3.C200 is used to extend the I/O bus or for the internal power supply +5V and +V (24V) to a module segment.

Please note the following rules:

- **Mandatory:** Insert a PCD3.C200 after the PCD3.M6893 and after each cable (at the start of a row).
- Use a maximum of five PCD3.K106/K116 cables.
- Do not use more than six PCD3.C200s in a single configuration, or the time delay will exceed the I/O access time.
- If an application is mounted in a single row (max. 15 module holders), then after five PCD3.C100 a PCD3.C200 must be used to amplify the bus signal (unless the configuration ends with the fifth PCD3.C100).
- If the application is mounted in multiple rows, the restricted length of cable means that only three module holders (1× PCD3.C200 and 2× PCD3.C100) may be mounted in one row.

**!** The following aspects should be considered when planning PCD3 applications:

- In keeping with lean automation, it is recommended to leave the first slot in the CPU basic module free for any subsequent expansions. This slot can accommodate simple I/O modules but also communication modules.
- The total length of the I/O bus is limited by technical factors; the shorter, the better.

**!** The following aspects should be considered for UL conform applications:

- The PCD3.M6893 base module may only be used with I/O modules listed in UL61010.
- The PCD3.M6893 base module is to be powered by an UL Class 2 certified power supply.
- Use only 60°/75° copper conductors.
- This device shall be installed in an industrial control panel or other suitable rated enclosure.
- If the equipment is used in a manner not specified by the manufacturer, the protection provided by the equipment may be impaired.

**!** PCD3 I/O modules are not hot-plug capable:

- Carefully insert and remove the I/O modules after switching off the power supply (24V).

# Power supply and connection concept

## External power supply

A two-way rectified supply can be used for most modules.

It is generally recommended to use robust and interference-resistant SBC power supply units with 24 VDC output.

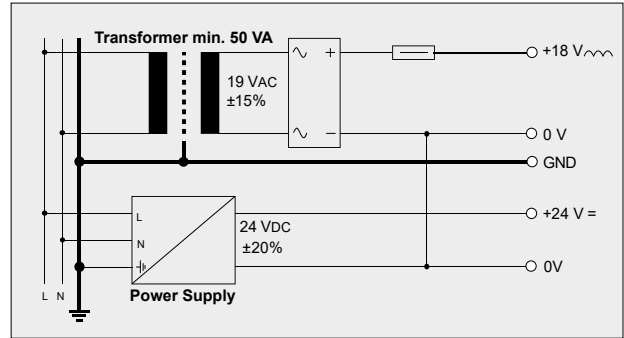

## Grounding and connection plan

- The zero potential (GND) of the 24 V supply is connected to the GND and the controller's grounding terminal. If possible, this should be connected to the ground bar with a short wire (<25 cm) with a cross section of 1.5 mm<sup>2</sup>. The same applies to the negative connection to the PCD3.F1xx or the interrupt terminal.
- Any shielding of analogue signals or communication cables should also be brought to the same grounding potential, either via a negative terminal or via the ground bar.
- All negative connections are linked internally. For flawless operation, these connections should be reinforced externally by short wires with a cross section of 1.5 mm<sup>2</sup>.

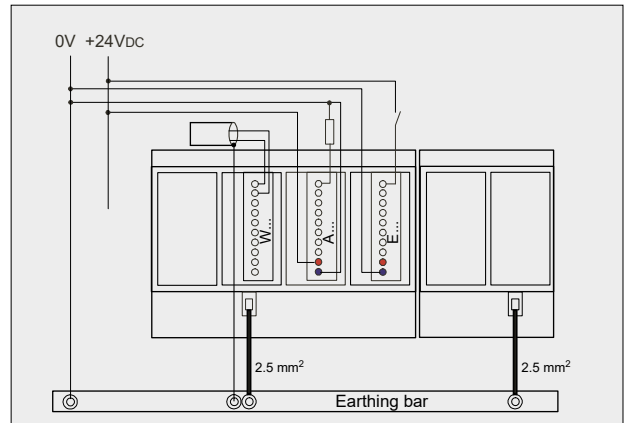

## Grounding and connection concept analogue inputs that are not electrically isolated (PCD3.W2x0, PCD3.W3x0)

Signal sources (such as temperature sensors) should be connected direct to the input module wherever possible. To obtain optimum measurement results, avoid connection to a ground bar. Additional external GND connections to the sensor signals may result in equalising currents which distort the measurement. If shielded cables are used, the shielding should be continued to a ground bar.

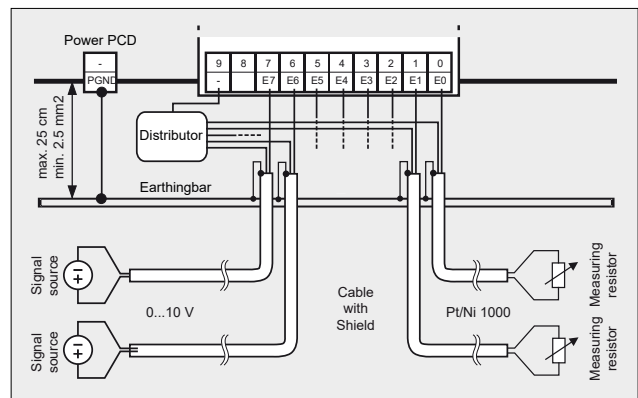
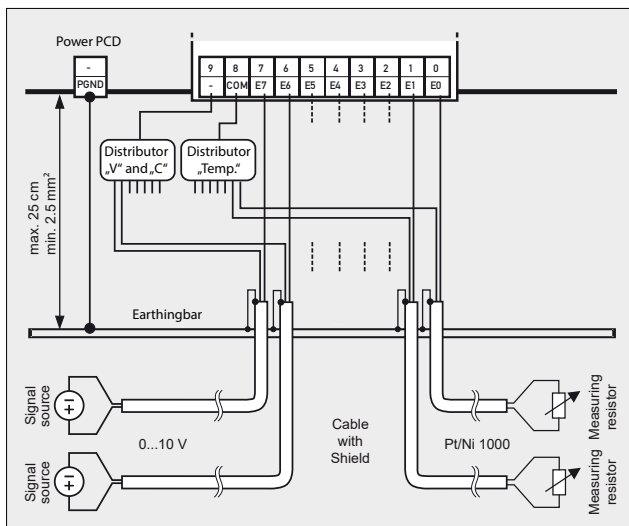

### Connection concept for PCD3.W2x0

The reference potential of signal sources must be wired to a common GND distributor at the “-” terminal

### Connection concept for PCD3.W3x0

The reference potential of voltage and current inputs must be wired to a common GND distributor at the “-” terminal. Temperature sensors must be wired to a common GND distributor at the “COM” terminal. The module PCD3.W380 has a 2-wire connection for the inputs and requires no external GND distributor.

## Extension module holders PCD3.C200 and PCD3.C100

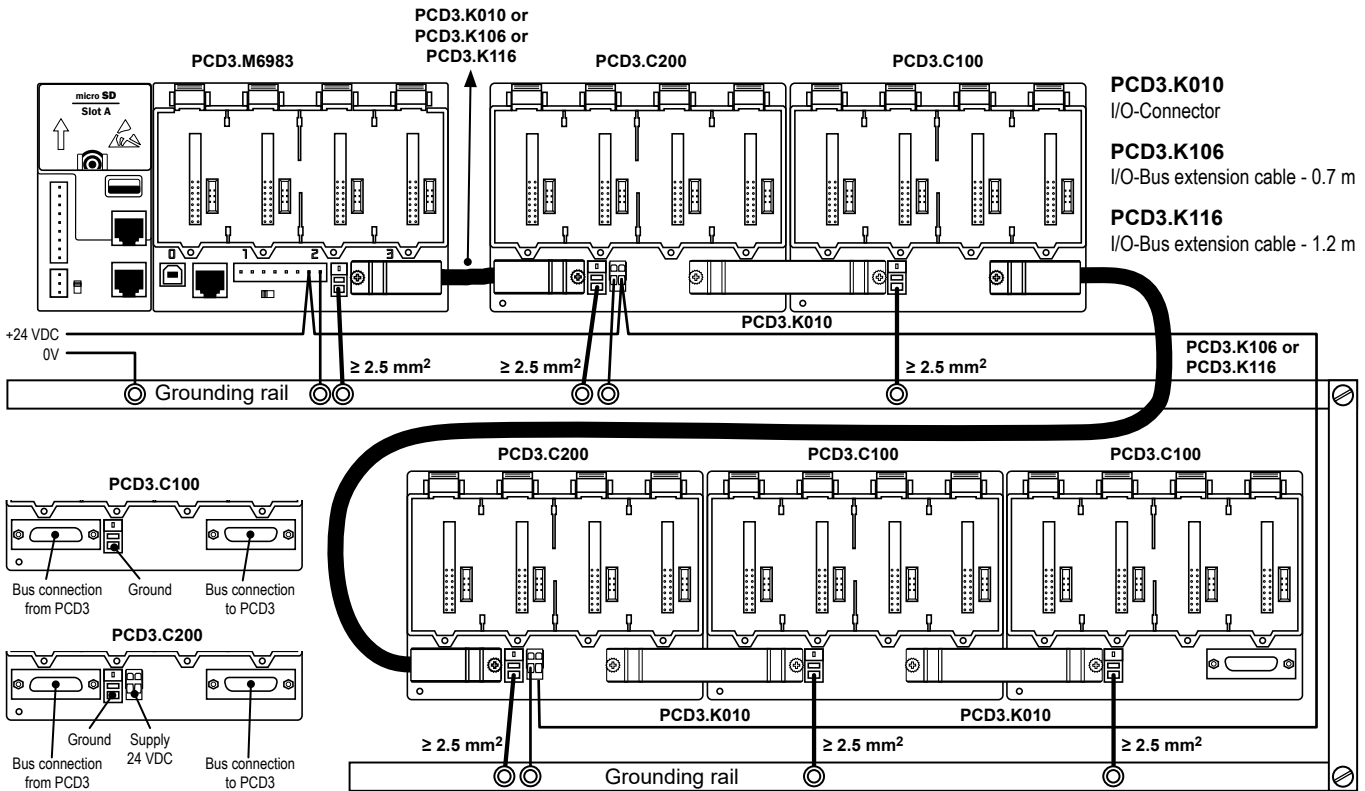

The PCD3.C200 module holders provide the following internal supply currents to the modules plugged in or connected to them:

	PCD3.C200
5V Bus	1500 [mA]
+V Bus	630 [mA]

Any shielding of analog signals or communication cables should also be brought to the same grounding potential, either via a negative terminal or via the ground bar.

All negative connections are linked internally. For flawless operation, these connections should be reinforced externally by short wires with a cross section of 1.5 mm<sup>2</sup>.

It is recommended to wire the I/O modules from a cable duct.

The following aspects should be considered when planning PCD3 applications:

- Insert a PCD3.C200 after each cable (at the start of a row)
- The total length of the I/O bus is limited by technical factors; the shorter, the better.
- Do not use more than six PCD3.C200s in a single configuration, or the time delay will exceed the I/O access time.

Conformity to CE directive	
This system is developed according to the international standard EN/IEC61131-2:2007 and so complies with European directives concerning EMC Directive 2014/30/EU, Low voltage Directive 2014/35/EU and Restricted of Hazardous substances (ROHS) 2011/65/EU.	

Certificates	
	EAC Mark of Conformity for Machinery Exports to Russia, Kazakhstan or Belarus

UL Compliance, according to the following conditions	
This device is suitable for use in a 55 °C maximum ambient!	
Use of 60/75 °C copper (CU) wire only.	
If use of Screw Terminal Maximum tightening torque 0.5 Nm.	

### WEEE Directive 2012/19/ EC Waste Electrical and Electronic Equipment directive

**WEEE Directive:**  
At the end of their useful life the packaging and product should be disposed of by a suitable recycling centre.  
Do not dispose of with normal household waste.  
Do not burn.

This symbol on our product shows a crossed-out "wheeled bin" as required by law regarding the Waste of Electrical and Electronic Equipment (WEEE) disposal. This indicates your responsibility to contribute in protecting the environment by proper disposal of this waste, i.e., not disposing of this product with your other wastes. To know the right disposal mechanism, please check the applicable law.

#### Further information and support

Further information and Software/QronoX are available on [www.sbc-support.com](http://www.sbc-support.com).

#### Disclaimer

The plant engineer contributes his share to the reliable operation of an installation. He is responsible for ensuring that controller use conforms to the technical data and that no excessive stresses are placed on it, e.g. with regard to temperature ranges, over voltages and noise fields or mechanical stresses. In addition, the plant engineer is also responsible for ensuring that a faulty product in no case leads to personal injury or even death, nor to the damage or destruction of property. The relevant safety regulations must always be observed. Dangerous faults must be recognized by additional measures and any consequences prevented. Consistent use of the diagnostic elements of the PCD, such as the watchdog, exception organization blocks (XOB) and test or diagnostic instructions shall be made.

### An example of power supply and connection concept

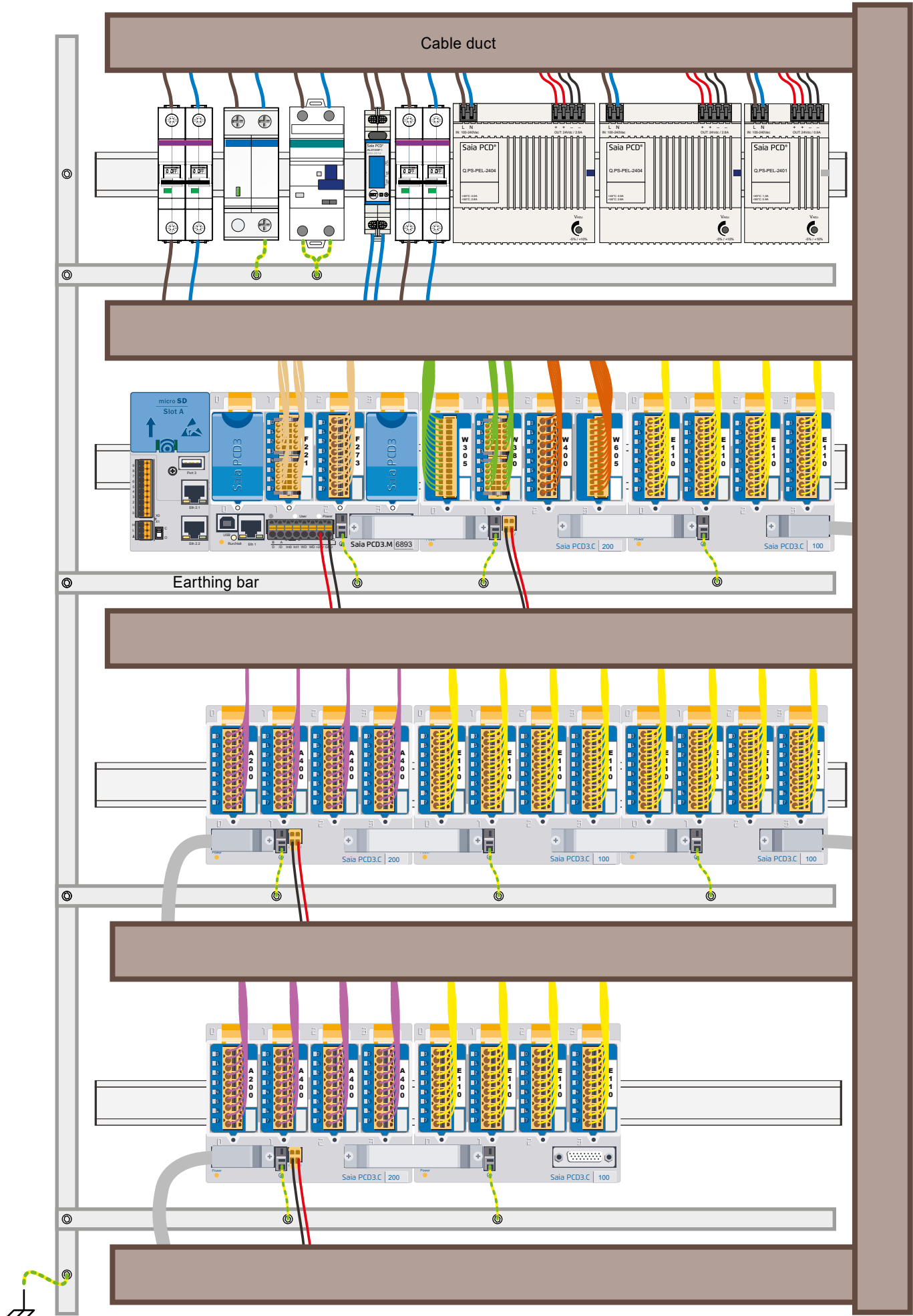



**ATTENTION**

These devices must only be installed by a professional electrician, otherwise there is the risk of fire or the risk of an electric shock.



**WARNING**

Product is not intended to be used in safety critical applications, using it in safety critical applications is unsafe.



**WARNING - Safety**

The unit is not suitable for the explosion-proof areas and the areas of use excluded in EN61010 Part 1.



**WARNING - Safety**

Check compliance with nominal voltage before commissioning the device (see type label).  
 Check that connection cables are free from damage and that, when wiring up the device, they are not connected to voltage.  
 Do not use a damaged device!



**NOTE**

In order to avoid moisture in the device due to condensate build-up, acclimatise the device at room temperature for about half an hour before connecting.



**CLEANING**

The device can be cleaned in dead state with a dry cloth or cloth soaked in soap solution.  
 Do not use caustic or solvent-containing substances for cleaning.



**MAINTENANCE**

These devices are maintenance-free.  
 If damaged, no repairs should be undertaken by the user.



**GUARANTEE**

Opening the module invalidates the guarantee.

Observe this instructions (data sheet) and keep them in a safe place.  
 Pass on the instructions (data sheet) to any future user.



WEEE Directive 2012/19/EC Waste Electrical and Electronic Equipment directive  
 The product should not be disposed of with other household waste. Check for the nearest authorized collection centers or authorized recyclers. The correct disposal of end-of-life equipment will help prevent potential negative consequences for the environment and human health.



EAC Mark of Conformity for Machinery Exports to Russia, Kazakhstan or Belarus.



UAE RoHS EASY certification

## Safety instructions for the PLC PCD3.M6893

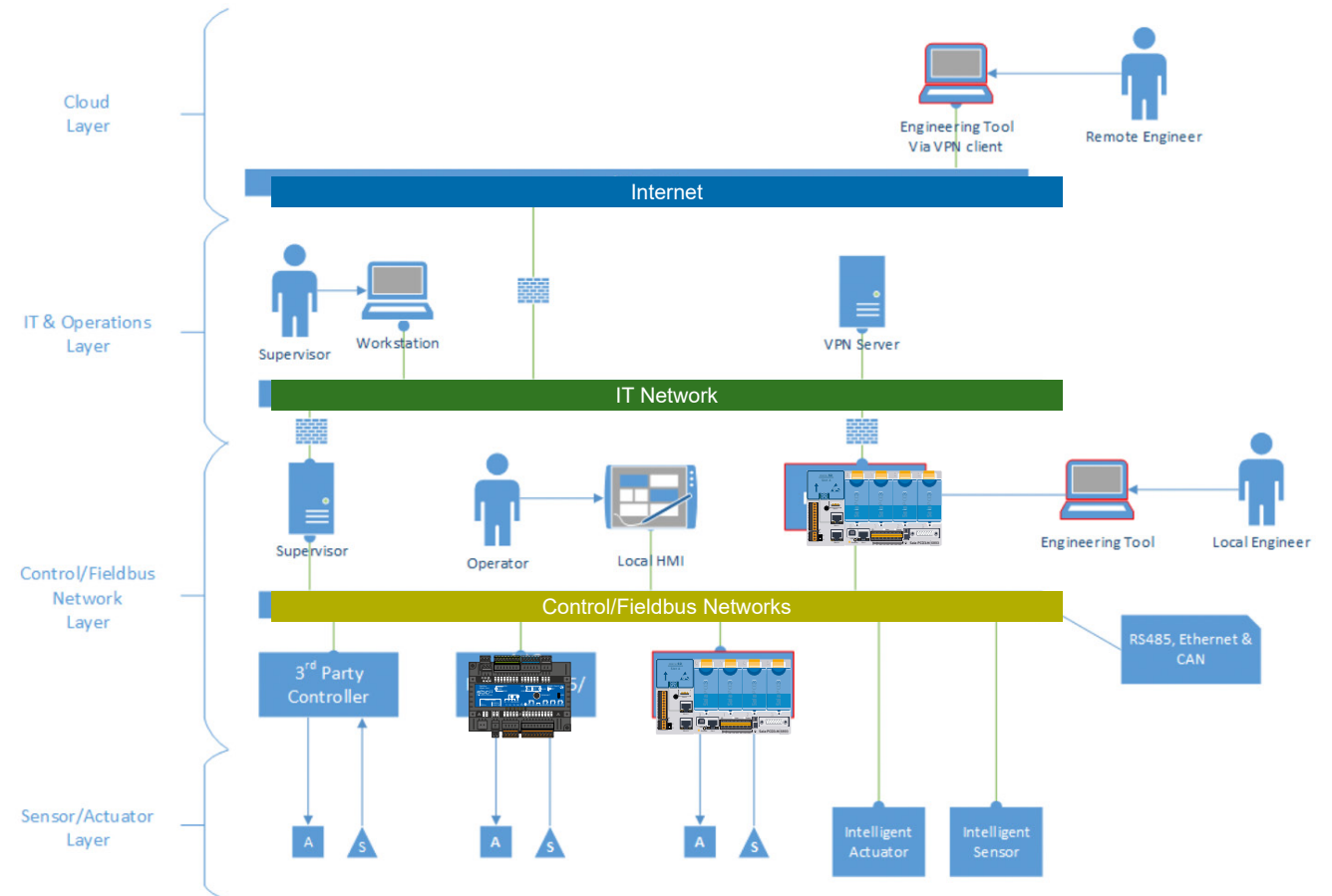

Saia PCD3.M6893 can be used in a highly networked environment and as such must be securely configured to reduce the risk of unauthorized access.

### Internet Connection

The device must not be connected directly to the internet without having proper precaution like a firewall between the Internet and the PCD3.M6893.

### Network Segmentation

The PCD3.M6893 is equipped with multiple network interfaces. The system traffic does not route between the interfaces. The system should be constructed as in the picture above. Having different networks for control and IT networks. Separate critical from non-critical elements by connecting them to different segments.

If networks cannot physically be separated, they at least must be firewalled off each other.

### Selection of Protocols

Whenever possible select encrypted and authenticated protocols.

### Firewall

While the PCD3.M6893 is equipped with a built-in firewall it is better to use dedicated firewall between the networks.

### Remote Access

In order to perform remote access to the system, a VPN must be used to tunnel network traffic securely from the remote engineering workstation into the IT network of the control infrastructure. The IT network should be configured in such a way that only the engineering tool communication protocol is allowed to pass from VPN network to the controller.

### Secure Remote Update

To update the firmware of a PCD3.M6893 controller, a VPN connection as outlined in section "Remote Access" is required. Once the VPN Server and Client are securely configured the use the firmware downloader in the engineering tool as usual to install the latest firmware for the PCD3.M6893

### Physical Access Control

Fieldbus networks are inherently insecure, also the PCD3.M6893 is not secured against physical modification like manipulating I/O modules and commonly used IT protocols like DHCP cannot be secured. It is therefore mandatory that the complete control infrastructure, including IT infrastructure and all equipment is physically protected against unauthorized access.

### Selection of Equipment

Only use equipment develop according to secure practices.

### Secure Development Practices

The PCD3.M6893 is freely programmable via IEC applications in the programming tool. Via SysXxxx and CAA libraries it is possible to access system resources of the operating system like file systems, serial interfaces, network interfaces, etc.(see [help.codeys.com](https://help.codeys.com)) While this level of access gives nearly unlimited flexibility it also requires discipline to develop IEC application in a secure manner.

This section of the manual outlines secure development practices that must be followed in order to have to keep the system secure. The secure practices outlined here are not comprehensive, be sure to consult specialized documentation like the OWASP ([https://www.owasp.org/index.php/OWASP\\_Secure\\_Coding\\_Practices\\_-\\_Quick\\_Reference\\_Guide](https://www.owasp.org/index.php/OWASP_Secure_Coding_Practices_-_Quick_Reference_Guide)).

### Input Data Validation

Treat all data from external entities as untrusted. This is especially the case when receiving data from an external interface like a serial line or a network interface. Validate all input data by type, length and use white list of acceptable values.

### Output Encoding

When storing data to a file or transmitting it over a network ensure proper escaping related to the output format.

### Communication Protocols

Implementing communication protocols requires special care. If the protocol allows use encrypted communication. If using TLS make sure you are using TLS 1.2 or higher only. If session identifiers are used, ensure that session ids are completely random, not reused and delete after a session has been terminated. Terminate the communication session if an invalid session id is used.

### Use of Watchdog

The system is equipped with two user programmable watchdogs. Watchdogs can be used to bring a system into a defined state when a task is running out of defined bounds.

#### Cycle Time Watchdog

In the 'Task Configuration' of an IEC application the Cycle Time watchdog can be programmed. Use this watch to protect against programming errors in individual tasks. If a task is exceeding the maximum allowed time, it will be killed by the runtime system.

#### Watchdog Relay

The system is equipped with a physical relays contact. The watchdog relays can be programmed in such a way, that the contact opens if it is not triggered in a configurable interval. By having the watchdog contact in line with the power supply as outlined below, it will allow to shut down the system completely in case the watchdog is not triggered in the defined interval.

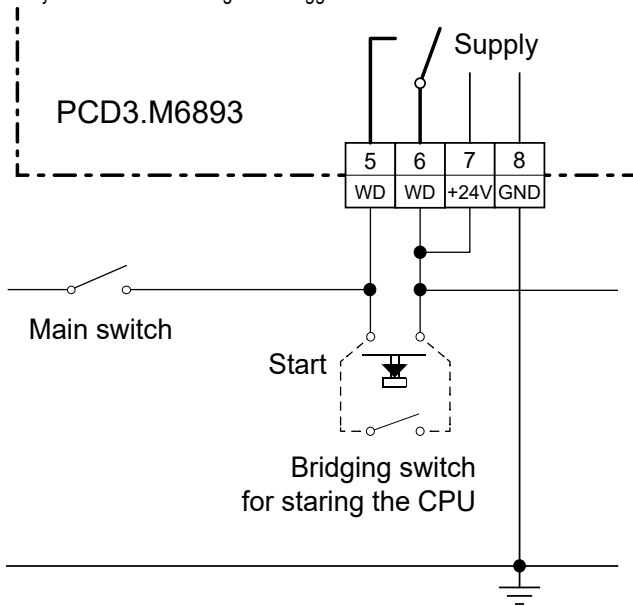

### Use of Task Priority

Cyclic tasks in IEC application can be assigned to different priorities, from background task to real-time tasks. Be sure to structure the task in such a manner, that only time critical tasks are running with real-time priority. No real-time task should have long running loops or should call synchronous SysXxxx functions as this may block the whole system.

### Use of IEC libraries

Only use libraries from trusted sources. Use the library manager to check that the library is correctly signed. Don't use libraries that are not signed or libraries of which the signature is invalid.

### Creating and distributing Libraries

Follow the guidelines part of the CODESYS manual. Ensure that the libraries are distributed as 'compiled' library otherwise the source code of the library is accessible for everyone having access to the library. Sign the library with your X.509 certificate.

## Secure Device Configuration

Follow the following guidelines to ensure a secure configuration of the PCD3.M6893 controller

### Network Ports

Disable all network ports that are not in use.

### Firewall

The PCD3.M6893 is equipped with a built in IP packet filter firewall. The firewall is by default configured so, that the programming tool on the USB service port is able to communicate with the device. All other traffic, in- our outbound is blocked by default. You must explicitly add rules to allow traffic to get in or out of the device. It is important that the firewall rules are as strict as possible. The firewall must be kept enabled, in order to add a layer of defense.

### Internet Detector

This device is not designed to be directly connected to the Internet. In order to protect against accidental Internet connection or misconfiguration of the firewall, the PCD3.M6893 is equipped with an Internet Detector service that disables the connecting port. This service is enabled by default and should be disabled if the device is located behind a properly configured firewall and Internet services must be consumed.

### Account management

The unified account management on the PCD3.M6893 provides a role-based account management that is used for all services on the device. Each service on the device allows fine grained access control for all data points and actions. Ensure that accounts are given permission on the principle of least privilege. That means, each account should only be given access to elements it really needs having access to in order that it can perform the desired operations. If an account is only supposed to be used for a limited time period, e.g. because the account is for an employee with limited contract term, make sure that is reflected in the account. Enable account lockout to prevent brute force attacks. Delete accounts that are no longer in use. Enable min. and max. password life time to force user to periodically change their password.

### Special Roles

Accounts with role 0 are Device Administrator accounts. Such accounts have full access on the device. Accounts with role 1 are User Administrator accounts. Such accounts manage other accounts as long as the managed accounts have the same or less roles than the device administrator account.



## Certificate Management

### General

The PCD3.M6893 is equipped with three services, CODESYS, HTTPS server and OPC UA, that uses digital encryption certificates to ensure the identity its communication party and/or to prove the device's own identity. At first startup, or factory reset, these services generate a self-signed certificate. While this helps commissioning the system it is not secure and must be changed before the system is put into operation.

### Do not put the PCD3.M6893 into operation with Self-signed certificates

The use of self-signed certificates is handy when in development, but products should not be shipped to customers with self-signed certificates. You should be either creating an initial certificate for your product or you should have a mechanism for the end customer to provision the product and allow them to assign a corporate signed certificate to the device.

You must inform you customer of the certificate management requirements of your product.

### CODESYS

The PCD3.M6893 uses a CODESYS RTS for the PLC functionality. The communication between QronoX ECS and the controller is always encrypted. The device generates an initial self-signed certificate. This certificate be exchanged by a custom certificate via the PLC shell inside of QronoX ECS. Consult the tools help for further information.

### HTTPs/Web Server

The HTTPs/Web Server of PCD3.M6893 supports custom certificates. The Web Server system configuration page in the programming tool allows installing a new certificate. The recommended way of doing so is to let the device generate a Certificate Signing Request (CSR). The CSR can be submitted to a trusted Certificate Authority (CA) which in turn issues the device certificate. This certificate can be installed via the Web Server system configuration page of the tool.

Consult the tool's help for further information.

### OPC UA

The OPC UA server of PCD3.M6893 can meet the strict security requirements of the OPC UA specification. This is only achievable if security in the system configuration is enabled and is used (the default is to have security enabled). As a product developer we strongly recommend ensuring secure channel communication is turned on in your product and the None-None-Anonymous security profile and the Accept all certificates option are only enabled if absolutely certain this is a requirement. Having security enabled and not having the None-None-Anonymous security profile as well as Accept all certificates off means all OPC UA clients connecting to your product must do so in a secure manner.

Please also check the available security profiles to ensure the type of security required matches what you are configuring for your environment. OPC UA server certificates, issuer certificates as well as trusted client certificates is done via the Files tab in the CODESYS Devices object

## Data Privacy

### Stored data on the device

The PCD3.M6893 stores the following data elements:

- Device configuration: IP address, Firewall rules, NTP configuration...
- User Management: Accounts, passwords, roles, permissions etc.
- Audit log: System log messages, all actions from all users...
- CODESYS: PLC application and CODESYS runtime system configuration.
- SD Card: Backups & user data

All data on the device is stored encrypted and is bound to the device. The only exception is backup files, which are encrypted but can be transferred to other devices and be restored there.

### Stored project data

Use project encryption to store project data. To do this, use the 'Security Screen' and set the project file encryption technology to 'Encryption'. Choose between password, dongle or certificates.

### Device Configuration

The device configuration can be changed with the programming tool by accounts with the appropriate access rights.

## Administration of Accounts

A device or account administrator can manage accounts on the device using the Device User Management node in the programming tool. The user management can only be uploaded and downloaded as one piece.

### Roles

Create roles to define permissions to the system. Available system functionalities can be enabled/disabled, or access rights can be set.

### Profiles

Create profiles to set up password and account settings. Assign roles to a profile to set the profile permissions.

### Accounts

Assign a profile to an account. Accounts can be locked or set to active/inactive for a certain period. A user or system has to login with a specific account to access the device.

### Deleting Audit Log

Device administrator accounts can delete the complete audit log by using the programming tool audit log viewer.

Programming tool projects.

## CODESYS

The PLC application can be changed and loaded with the programming tool. Only device administrators can do that.

### SD Card

That data on the user file system, as well as the backup files on the SD card can be managed via the File System Explorer in the programming tool. Access to the SD card data is restricted to Device Administrator accounts.

### Erase All Data/Factory Reset

All data on the device can be delete by pressing the service button for 30 seconds when during system power up.

### Data Privacy Statement

Saia-Burgess Controls AG's privacy statement can be found here:

<https://www.saia-pcd.com/en-gb/privacy-statement/>

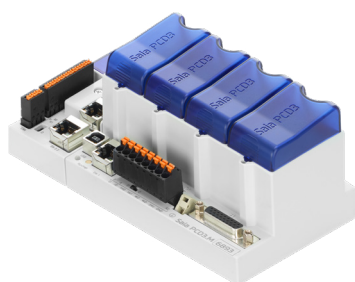

PCD3.M6893

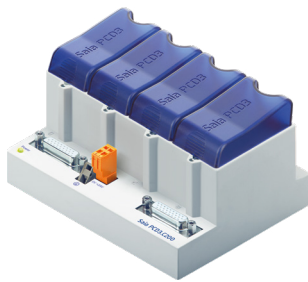

PCD3.C200

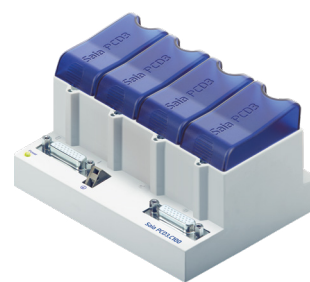

PCD3.C100

## Order details

Type	Short description	Description	Weight
PCD3.M6893	CPU base units for 4 plug-in I/O modules	PCD3 controller without battery with 1 GByte RAM and 2 GByte Flash for operating system and user program, 1 Socket for user data micro-SD card, max. 32 GByte, 2 Ethernet, 1 RS-485, 1 socket for communication modules, 1 USB Device port for programming and service, 1 USB host, 1 CAN port (20a and 20b on demand) 2 interrupt inputs, 1 watch dog relay, extendable up to 1023 I/O. Supported PCD3 - I/O Modules: PCD3.Ax, PCD3.Ex, PCD3.W2x, PCD3.W3x, PCD3.W4x, PCD3.W6x, PCD3.W745, PCD3.W800 and PCD3.S100	560 g
PCD3.C200	Extension module holder	Extension module holder for 4 I/O modules with terminal connectors for external 24 VDC power supply	440 g
PCD3.C100	Extension module holder	Extension module holder for 4 I/O modules	420 g
PCD3.R010	Battery module	Battery module for PCD3.M3xx0, plug-in onto I/O Slot #3	60 g
PCD7.R-MSD1024	Micro SD card 1024 MB	Saia PCD® uSD Flash memory card 1024 MByte (included SD Flash adapter)	10 g

Slot covers  
410475150 /  
4104750208-pin  
spring terminal block  
32341564-00110-pin  
spring terminal block  
32341217-0013-pin  
spring terminal block  
32341216-001Connecting plug  
PCD3.K010Extension cable 0.7 / 1.2 m  
PCD3.K106 / PCD3.K116

## Accessories

Type	Short description	Description	Weight
32341564-001	8-pin spring terminal block	Plug-in spring terminal block, 8-pole 0.2...2.5 mm <sup>2</sup> (black block)	15 g
32341217-001	10-pin spring terminal block	Plug-in spring terminal block, 10-pole, 0.14...1.5 mm <sup>2</sup> (black block), labelled 0 to 9	7 g
32341216-001	3-pin spring terminal block	Plug-in spring terminal block, 3-pole, 0.14...1.5 mm <sup>2</sup> (black block), labelled 0 to 2	3 g
410475150	Slot cover	Slot cover for unused PCD3 I/O slots (with SBC logo)	8 g
410475020	Slot cover	Slot cover for unused PCD3 I/O slots (neutral - without SBC logo)	8 g
PCD3.K010	Connection plug	Connection plug PCD3.M/T/C to PCD3.Cx00	40 g
PCD3.K106	Extension cable 0.7 m	Extension cable for PCD3.M/T/C to PCD3.Cx00 (length 0.7 m)	140 g
PCD3.K116	Extension cable 1.2 m	Extension cable for PCD3.M/T/C to PCD3.Cx00 (length 1.2 m)	180 g



**Saia-Burgess Controls AG**  
Route Jo-Siffert 4 | 1762 Givisiez, Switzerland.  
Switchboard: T +41 26 580 30 00  
Support: T +41 26 580 31 00  
[www.saia-pcd.com](http://www.saia-pcd.com)  
[support@saia-pcd.com](mailto:support@saia-pcd.com) | [www.sbc-support.com](http://www.sbc-support.com)