

PCD3.W210

Analog input module, 8 channel, 10 bit,
0 ... 20 mA (4 ... 20 mA via software)

Description

Fast, analog 8 channel input module with 0 ... 20 mA (4 ... 20 mA via software) and 10 bit resolution per channel. With its short conversion time of <math>< 50 \mu\text{s}</math>, this module is universally suitable for recording analogue signals.

Technical specifications	
Number of inputs (channels)	8
Signal range	0 ... 20 mA (4 ... 20 mA via Software)
Resolution (representation)	10 bit (0 ... 1023)
Galvanic separation	no
Measuring principle	non-differential, single-ended
Input resistance	125 Ω / 0.1 %
Accuracy (of measured value)	± 3 LSB
Repeating accuracy (under same conditions)	within 1 LSB
Temperature error (0 ... +55 °C)	± 0.3 % (± 3 LSB)
Conversion time A/D	$\leq 50 \mu\text{s}$
Overcurrent protection	± 40 mA
Burst protection (IEC1000-4-4)	± 1 kV, with unshielded cables ± 2 kV, with shielded cables
Time constant of input filter	typically 1 ms
Internal current consumption (from +5 V bus)	8 mA
Internal current consumption (from V+ bus)	5 mA
External current consumption	0 mA
Terminals	Pluggable 10-pole spring terminal block for \varnothing up to 2.5 mm ² , plug type A



PCD3.W210

Indicators and connections

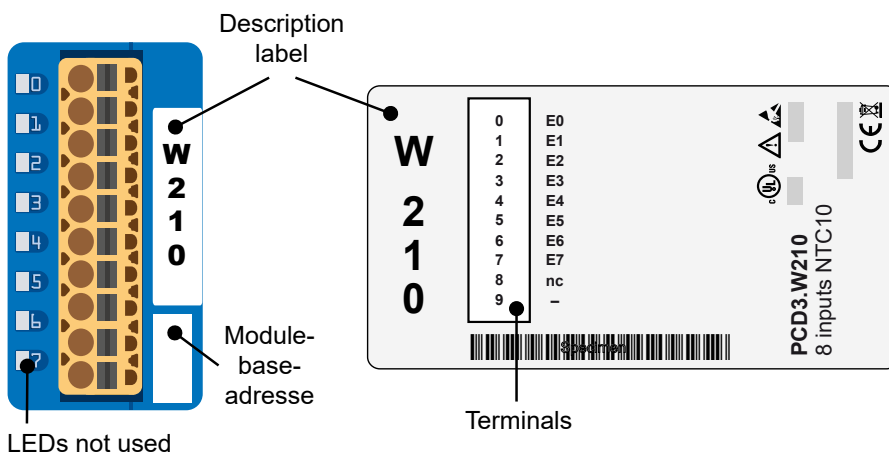

Block diagram

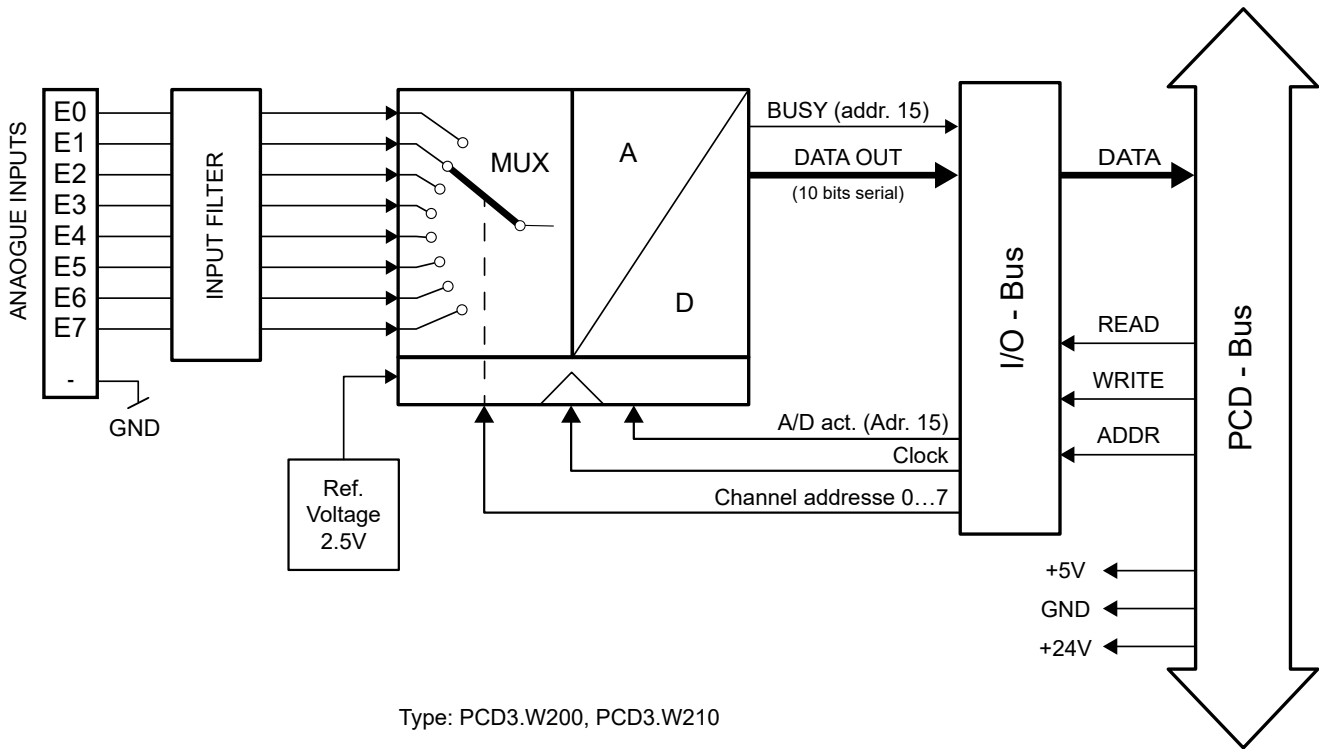

Connection concept for two-wire transmitter

The input signals are connected directly to the 10-pole terminal block (E0 ... E7 and COM). To minimize the amount of interference coupled into the module via the transmission lines, connection should be made according to the principle explained below.

Connection for 0...20 mA two-wire transmitter

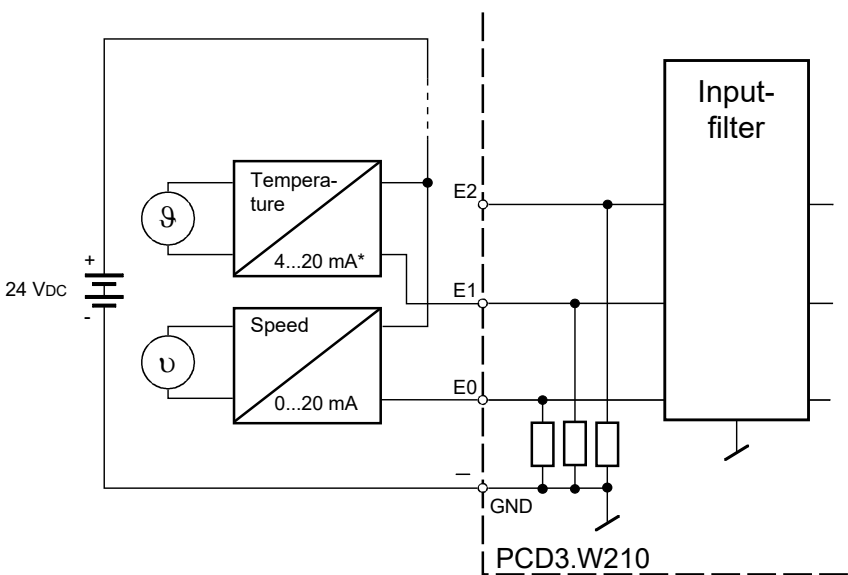

*4...20 mA via userprogramm

- The reference potentials of signal sources should be wired to a common GND connection (“-” and “COM” terminals). To obtain optimum measurement results, any connection to an earthing bar should be avoided.
- If shielded cables are used, the shielding should be connected to an earthing rail.
- Input signals with incorrect polarity significantly distort the measurements on the other channels.

Two-wire transducers (0...20 mA and 4...20 mA transmitters) need a 24 VDC supply in the measuring trunk.

Configuration

Saia PCD® Classic

PCD-System	Evaluation
------------	------------

Classic
The evaluation is performed by the firmware. It reads the values according to the configuration (Device Configurator or Network Configurator).

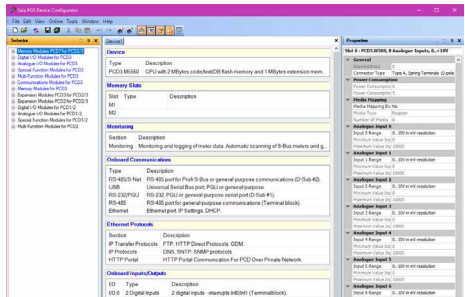

Alternatively An FBox "PCD2/3.W2" exists for evaluation.

FBox for PCD3.W210 (Inputs 0...7 selectable)

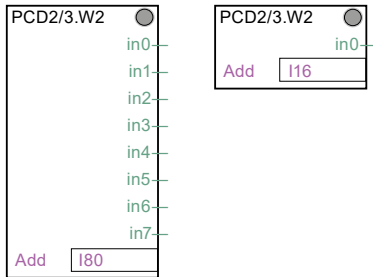



Saia PCD® IEC-Controller

PCD-System	Evaluation
------------	------------

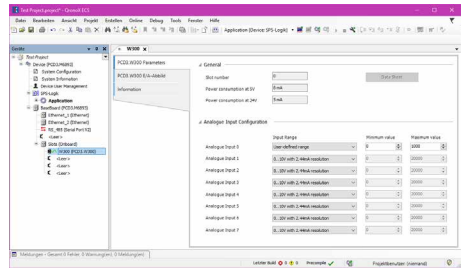
IEC-Controller
The evaluation is performed by the firmware. It reads the values according to the configuration (Device Configurator)



	<p>Watchdog: This module can interact with the watchdog, if it is used on base address 240. For details, please refer to the manual "27-600_I/O-modules for PCD1 / PCD2 series and for PCD3" in chapter "A4 Hardware Watchdog", which describes the correct use of the watchdog together with PCD components.</p> <p>Watchdog: This does not apply when used in PCD3.M6893.</p>
	<p>I/O modules and I/O terminal blocks may only be plugged in and removed when the Saia PCD® and the external +24 V are disconnected from the power supply.</p>
	<p>Further information can be found in the document: "27-600 ENG Manual I/O-Modules for PCD1 / PCD2 and PCD3"</p>

**ATTENTION**

These devices must only be installed by a professional electrician, otherwise there is the risk of fire or the risk of an electric shock.

**WARNING**

Product is not intended to be used in safety critical applications, using it in safety critical applications is unsafe.

**WARNING - SAFETY**

The unit is not suitable for the explosion-proof areas and the areas of use excluded in EN61010 Part 1.

**WARNING - SAFETY**

Check compliance with nominal voltage before commissioning the device (see type label). Check that connection cables are free from damage and that, when wiring up the device, they are not connected to voltage. Do not use a damaged device !

**NOTE**

In order to avoid moisture in the device due to condensate build-up, acclimatise the device at room temperature for about half an hour before connecting.

**CLEANING**

The device can be cleaned in dead state with a dry cloth or cloth soaked in soap solution. Do not use caustic or solvent-containing substances for cleaning.

**MAINTENANCE**

These devices are maintenance-free.
If damaged, no repairs should be undertaken by the user.



Observe this instructions (data sheet) and keep them in a safe place.
Pass on the instructions (data sheet) to any future user.

**WEEE Directive 2012/19/EC Waste Electrical and Electronic Equipment directive**

The product should not be disposed of with other household waste. Check for the nearest authorized collection centers or authorized recyclers. The correct disposal of end-of-life equipment will help prevent potential negative consequences for the environment and human health.



EAC Mark of Conformity for Machinery Exports to Russia, Kazakhstan or Belarus.



PCD3.W210



4 405 4954 0

Ordering information			
Type	Short description	Description	Weight
PCD3.W210	8 analogue inputs 0...20 mA, 10 bit	Analogue input module, 8 inputs (channels), resolution 10 bit, signal range 0...20 mA (4...20 mA via software), the channels themselves not separated, connection with pluggable spring terminals, plug-in type A ((4 405 4954 0) included	80 g

Ordering information equipment			
Type	Short description	Description	Weight
4 405 4954 0	Plug-in, type A	Plug-in I/O spring terminal block, 10-pole up to 2.5 mm ² , labelled 0...9	15 g