

Q.RCU-A-xxxx Series

Analog room control unit



Product Description

The Q.RCU-A-T series of analog wall sensors is designed to interface with controllers of fan coil, heat pump, roof top and terminal heating / cooling units. These sensors provide precision local temperature measurement with the capability of local setpoint adjustment, fan speed setting, and occupancy override.

The Q.RCU-A-T's modern, alluring profile enclosure is suitable for classrooms, hotels, executive areas, office spaces and other commercial areas. Mounting hardware with a separate sub-base is provided with the device for installation on a dry wall or on an electrical junction box.

This document describes the hardware installation procedures for the following device models: Q.RCU-A-T, Q.RCU-A-TO, Q.RCU-A-TS, Q.RCU-A-TSO, and Q.RCU-A-TSOF.

Unless otherwise indicated, the term Q.RCU-A-xxxx will be used in this document to represent all the models of the Q.RCU-A-T Series

General Installation Requirements

For proper installation and subsequent operation of the Q.RCU-A-T, pay special attention to the following recommendations:

- Upon unpacking the product, inspect the contents of the carton for shipping damages. Do not install damaged sensors.
- Allow for proper clearance of device enclosure and wiring terminals for easy access, hardware configuration and maintenance.
- The device is designed to operate under the following environmental conditions:
 - Ambient temperature from 0°C to 50°C
 - Relative humidity from 0% to 90%, non-condensing.
- Ensure proper ventilation of device and avoid areas where corroding, deteriorating or explosive vapors, fumes or gases may be present. The device must be oriented with the ventilation slots towards the top to permit proper heat dissipation.



Any type of modification to any SBC product will void the product's warranty.



Take reasonable precautions to prevent electrostatic discharges to the device when installing, servicing or operating it. Discharge accumulated static electricity by touching one's hand to a securely grounded object before working with the device.

General Installation Requirements



Turn off power before any kind of servicing.

- All wiring must comply with electrical wiring diagrams as well as national and local electrical codes.
- To connect the wiring to the device, use the terminal connectors which are located inside the device's enclosure. Use a small flat screwdriver to tighten the terminal connector screws once the wires have been inserted.
- The board connectors accept wires or flat cables ranging from
- 0.64...1.63 mm diameter per pole.
- It is recommended that all terminals be wired by 18 AWG wire except for network communications.

Device Components

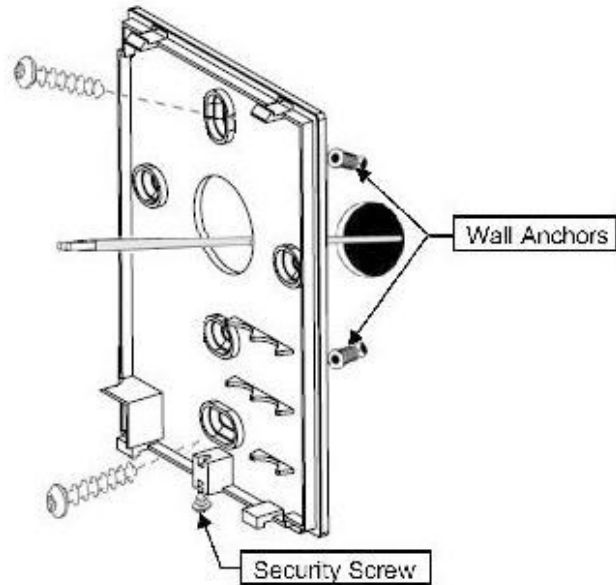

Figure 1: Mounting a Smart-Sensor

Device Dimensions

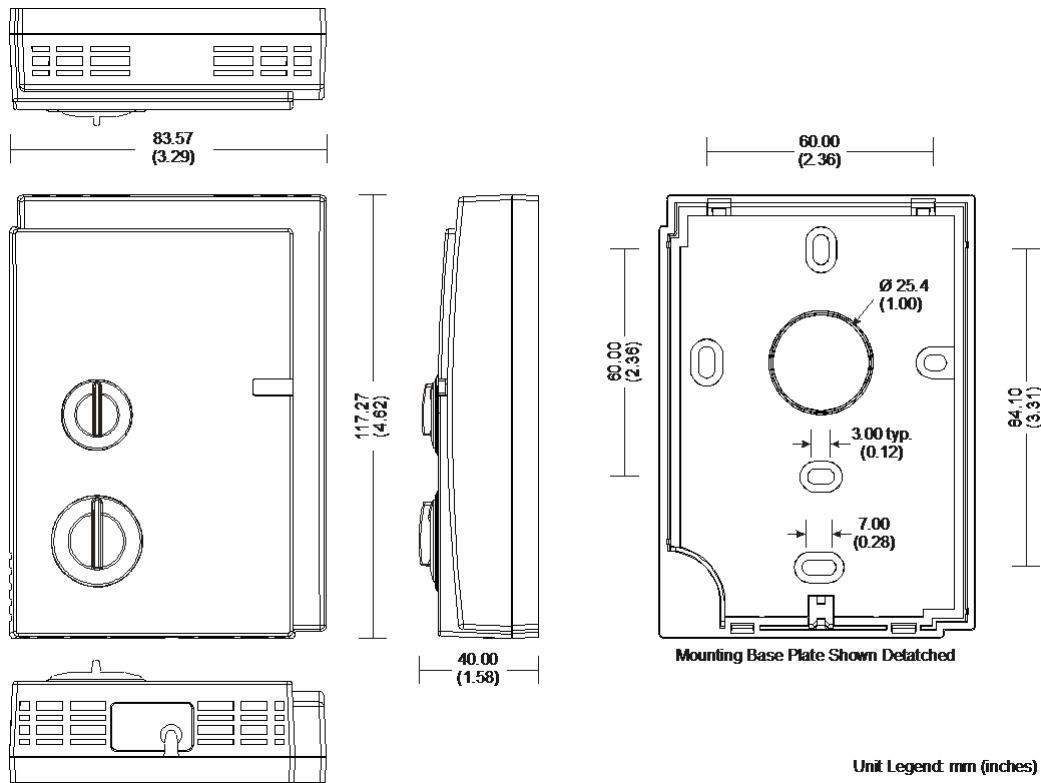

Figure 2: From mid left to right: Front view, side view, back plate

Mounting Instructions

The Q.RCU-A-xxxx has been specially designed for easy installation. However, certain conditions apply when choosing a suitable location for the device:

- Install the device in a location of average temperature approximately 1.5 m above the floor
- The device should not be installed on an exterior wall. The device should not be installed near a heat source.
- The device should not be installed near an air discharge grill. The device should not be installed in a place where it can be
- affected by the sun.
- Install the device in an area that provides proper device ventilation. Nothing must restrain air circulation to the device.



The Q.RCU-A-xxxx has not been designed for outdoor use.

Wall Mounting Installation Procedure

1. Remove the security screw from the device (Figure 5-1).
2. Open the device by pressing in the two (2) tabs on the bottom of the device and pulling the bottom side of the front plate out. Pull all cables 6" out of the wall, and insert them through the
3. central hole of the back plate.
4. Align the back plate with the wall and mark the location of the mounting holes on the wall. Make sure to orient the proper side of the back plate facing upwards.
5. Remove the back plate and drill holes in the wall if necessary. Install anchors in the wall if necessary.
6. Make sure that the mounting surface is flat and clean. Screw the back plate onto the wall. **Do not over tighten.**
7. Strip each wire ¼" and insert each one according to the wiring diagrams shown in this document.
8. Gently push excess wiring back into the wall.
9. Reattach the front plate and make sure it clips tightly into place. Install security screw.
10. CU-D-L Light/Blind add-on modules front plates (if applicable).

Electrical Junction box Installation Procedure

The Q.RCU-A-xxxx can be mounted most American, European and Asian style electrical junction box using screws.

11. Remove the security screw from the device (Figure 5-1).
12. Open the device by pressing in the two (2) tabs on the bottom of the device and pulling the bottom side of the front plate out.
13. Pull all cables 6" out of the wall, and insert them through the
14. central hole of the back plate.
15. Screw the back plate onto the electrical junction box.
16. Strip each wire ¼" and insert each one according to the wiring
17. diagrams shown in this document.
18. Gently push excess wiring back into the electrical junction box. Reattach the front plate and make sure it clips tightly into place. Install security screw.

Device Wiring

The Q.RCU-A-xxxx has physical connections for up to four (4) different features depending on the model. These features include the following:

- Thermistor
- Setpoint potentiometer
- Status LED indicator Fan speed
- rotary switch

Wiring the 10 kΩ Thermistor

Terminals TEMP and COMMON are used for the 10 kΩ type 2 NTC thermistor, as well as for the override button (not available on Q.RCU-A-xxxx and Q.RCU-A-TS models). These two terminals are present on every Q.RCU-A-xxxx model.

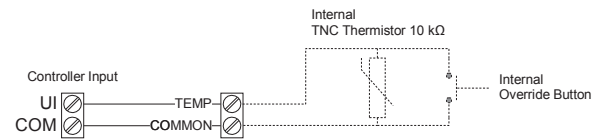

Figure 3: 10 kΩ NTC Thermistor input



The override button creates a short circuit on the controller input, which is interpreted as an override signal.

Wiring the 10 kΩ Thermistor and the Setpoint Potentiometer

Terminals SETPOINT and COMMON are used for the 10 kΩ setpoint potentiometer. These terminals are present on the Q.RCU-A-TS, Q.RCU-A-TSO, and Q.RCU-A-TSOF models.

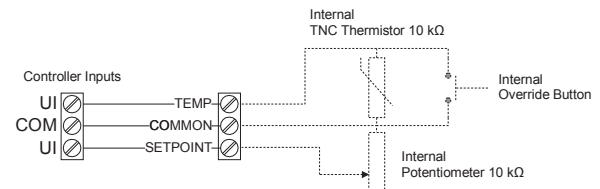

Figure 4: 10 kΩ NTC Thermistor and setpoint potentiometer inputs

Wiring a Status LED indicator

Terminals LED and COMMON are used to connect a controller output to the status LED indicator. These terminals are present on the Q.RCU-A-TO, Q.RCU-A-TSO, and EC- Sensor-SOF.

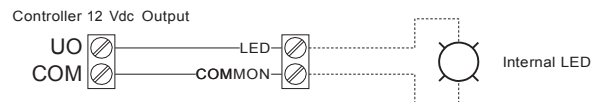

Figure 5: Status LED indicator output

Wiring a Five-Position Fan Speed Rotary Switch

Terminals FANSPEED and COMMON are used to connect the five internal preset resistance values of the fan speed rotary switch to a controller input. These terminals are present on the Q.RCU-A-TSOF model. The following table shows the five fan speed settings and their corresponding resistance values.

Fan Speed Setting	Corresponding Resistance Value
Auto	0 Ω
Off	2.5 k Ω
Fan Speed 1	5.0 k Ω
Fan Speed 2	7.5 k Ω
Fan Speed 3	10.0 k Ω

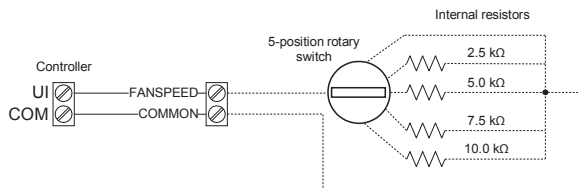

Figure 6: Five-position fan speed input

Document History

Version	Changes	Published	Comments
ENG01	2016-03-23	2016-03-23	First edition

Trademarks

Saia PCD[®] is a registered trademark of Saia-Burgess Controls AG, short form SBC.

Technical changes are subject to the state of technology.

Saia-Burgess Controls AG, 2016. © All rights reserved.

Postal address for returns from customers of the Swiss Sales office

Saia-Burgess Controls AG
 Service Après-Vente
 Bahnhofstrasse 18
 3280 Murten, Switzerland

Saia-Burgess Controls AG

Bahnhofstrasse 18 | 3280 Murten, Switzerland
 T +41 26 580 30 00 | F +41 26 580 34 99
 www.saia-pcd.com

support@saia-pcd.com | www.sbc-support.com