

S0 pulse counter

with S-Bus interface

The S0-S-Bus coupler module is a device for the collection of S0 pulses. With this module the consumption data of any measurement device with a S0 output becomes bus capable and can be accessed by every Saia PCD® or Energy Manager through the S-Bus.

Main features:

- Up to 100 S0-S-Bus Modules on the same bus
- 4 S0 pulse inputs (S01+... S04+) per S0-S-Bus Module
- Up to 400 S0 devices on the same S-Bus
- The inputs comply with the S0 standard 62053-31
- Integrated RS-485 termination resistor
- LED for bus activity indication

Order number

PCD7.H104SE



Technical Data

Protection type as DIN40050	IP 40 connections IP 20
Operating voltage Un	230 VAC (-20/+15%)
Current draw	< 12 mA
Power draw	< 3 W
Temperature	- Operation -25°C ... +55°C - Storage -25°C ... +70°C
EMC / noise immunity	- Surge voltage according to IEC61000-4-5 on main electric circuit, 4 kV 1.2 / 50 µs - Surge voltage according to IEC61000-4-5 at S0 inputs, 1 kV 1.2/50 µs - Burst voltage according to IEC61000-4-4 - Main electric circuit 4 kV direct - S0 inputs 2 kV capacitive - S-Bus connections 1 kV capacitive - ESD according to IEC61000-4-2, - Contact 8 kV, air 8 kV
Insulation characteristics	- 4 kV/50 Hz test according to VDE0435 - 6 kV 1.2 / 50 µs surge voltage according to IEC61000-4-5 - Device protection class II
LEDs	- Run indication by green LED (On) - Function indication by red LED when bus active

Mounting

Mounting	On 35 mm DIN top-hat rail (EN50022) any mounting position
Connections	- For Pozidrive, Philips or slot-head screwdriver N°1 - S0x, S-Bus, 230 VAC 0.5 ... 2.5 mm ²

Dimensioned drawings

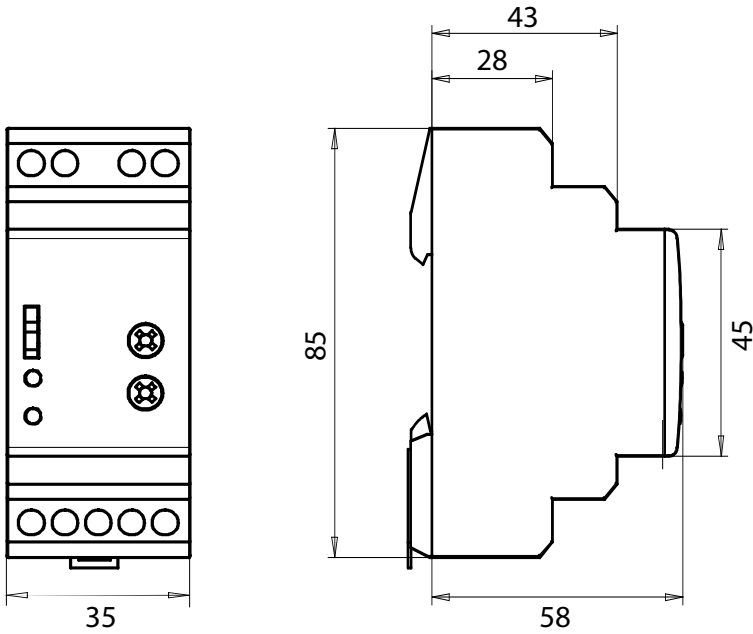

Display elements / settings

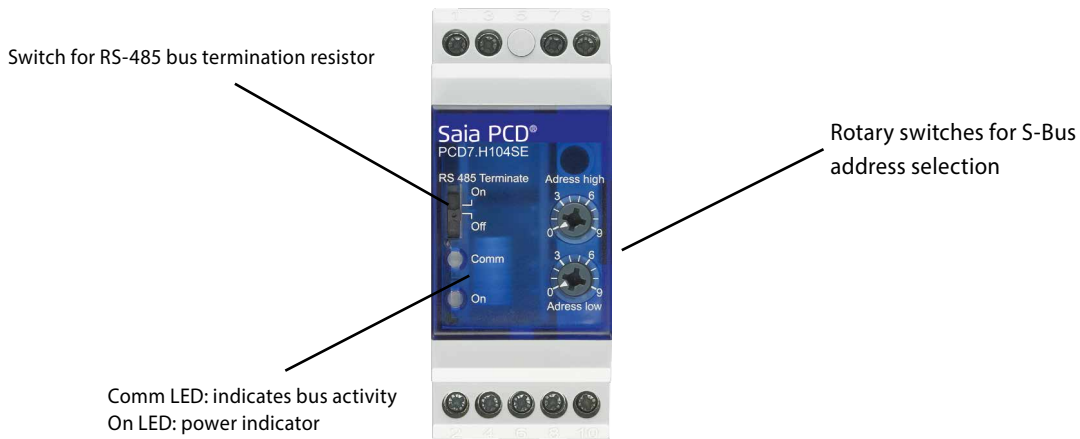

S0 inputs

- ▶ Comply with S0 standard EN62053-31
- ▶ Counts pulses as 0 when $R < 800 \Omega$
- ▶ Counts pulses as 1 when $R > 1 \text{ M}\Omega$
- ▶ Voltage max. (GND-S0) 13 VDC
- ▶ Current max. (with 0 Ω) 6 mA
- ▶ Pulses low min. 30 ms
- ▶ Pulses high min. 30 ms
- ▶ Frequency max. 17 Hz

Changing the S-Bus-Address

- ▶ Switch off 230 VAC
- ▶ Set new address
- ▶ Switch on 230 VAC

Note:

The address setting will only be read when the module supply (230 VAC) is switched on.

Wirings Diagram

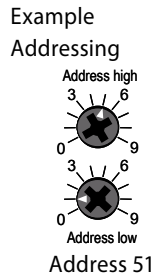
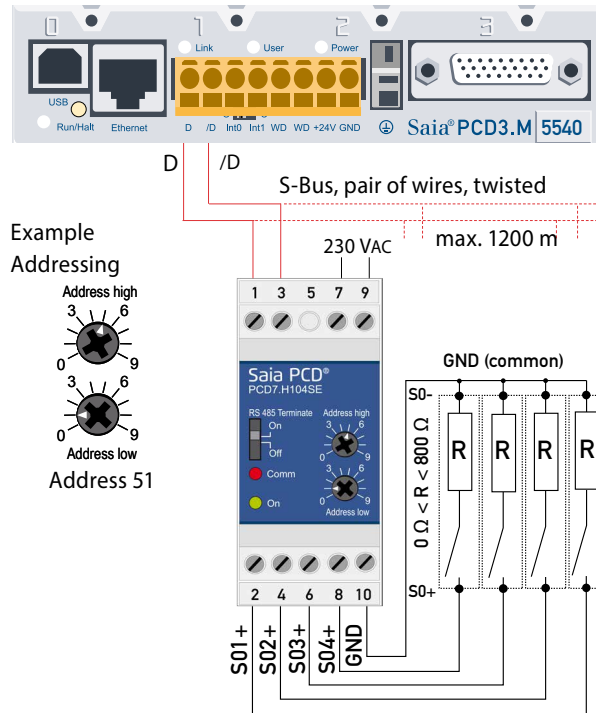

Note: If the S0-S-Bus module is used in the S-Bus as last device, then the sliding switch «RS-485 Terminate» need to be in the position «On».

Technical data S-Bus

Bus system	S-Bus
Transmission rate	2400-4800-9600-19'200-38'400-57'600-115'200. The transmission Baud rate is automatically detected
Transmission mode	Data
Bus length (max.)	1200 m (without repeater)
Response time:	Write: 30 ms Read: 20 ms

- ▶ The communication is ready 30 s after the Power On
- ▶ For a description of the used Registers please look at the Register Page

Data transmission

- ▶ Only «read/write» register instructions are recognized.
- ▶ Only one register can be written at a time.
- ▶ The device will respond «NAK» if more than 1 register is written.
- ▶ Up to 20 Registers could be read at a time.
- ▶ The device will respond «NAK» if more than 20 registers are read.
- ▶ The device will not respond to any unknown query.
- ▶ The device has a voltage monitoring system. In case of voltage loss, registers are stored in EEPROM (transmission rate» etc.)

Register

R	Read	Write	Description	Unit or Value
0	X		Firmware-Version	Ex: «10»= FW 1.0
1	X		S-Bus com. number of supported registers	will give «38»
2	X		S-Bus com. number of supported flags	will give «0»
3	X		Baudrate	BPS
4			Not used	will give a «0»
5	X		Type/ASN Function	will give «PCD7»
6	X		Type/ASN Function	will give «H104»
7	X		Type/ASN Function	will give «SE»
8	X		Type/ASN Function	will give «0»
9	X		HW Vers. Modif	Ex: «10»= HW 1.0
10			Not used	will give a «0»
11			Not used	will give a «0»
12	X		serial number	will give the serial number
13			Not used	will give a «0»
14	X		Status/Protect	«0» = no Problem «1» = Problem with last communication request
15	X		S-Bus Timeout	ms
16	X		S-Bus Address	0-99
17			Not used	will give a «0»
18			Not used	will give a «0»
19			Not used	will give a «0»
20	X	X	Counter S01	Ex: 912351 = 912351/2000 = 456.2 kWh
21	X	X	Counter S02	Ex: 912351 = 912351/2000 = 456.2 kWh
22	X	X	Counter S03	Ex: 912351 = 912351/2000 = 456.2 kWh
23	X	X	Counter S04	Ex: 912351 = 912351/2000 = 456.2 kWh
24	X	X	Impulses per unit for S01	Ex: 2000 = 2000 Imp/kWh
25	X	X	Impulses per unit for S02	Ex: 2000 = 2000 Imp/kWh
26	X	X	Impulses per unit for S03	Ex: 2000 = 2000 Imp/kWh
27	X	X	Impulses per unit for S04	Ex: 2000 = 2000 Imp/kWh
28	X	X	ID for S01	User defined identification number
29	X	X	ID for S02	User defined identification number
30	X	X	ID for S03	User defined identification number
31	X	X	ID for S04	User defined identification number
32			Not used	will give a «0»
33			Not used	will give a «0»
34			Not used	will give a «0»
35			Not used	will give a «0»
36	X	X	Transmission speed	1: 115'200 2: 57'600 3: 38'400 4: 19'200 5: 9600 6: 4800 7: 2400
37	X	X	Auto-Baud ON	0: Auto-Baud detect OFF 1: Auto-Baud detect ON

Saia-Burgess Controls AG

Bahnhofstrasse 18 | 3280 Murten, Switzerland
T +41 26 580 30 00 | F +41 26 580 34 99
www.saia-pcd.com

support@saia-pcd.com | www.sbc-support.com