

ControlsNews

The customer magazine of Controls Division



saia-burgess

Control Systems and Components

- Saia® PCD
- Saia® PCD
- Saia® PCD
- Saia® PCD
- Saia® PCD
- Saia® PCD
- Saia® PCD
- Saia® PCD

Saia®PG5 – new version 2.0

Saia®PCD Web-Panel family keeps growing

High investment volume for Controls

New PLC generation Saia®PCD2.M5





Jürgen Lauber
Managing Director Saia-Burgess Controls

«Saia® with your pizza PLC...»

Dear Reader

In my early days with Saia®, when I heard this for the first time from a customer, I felt somehow offended. Now I take it as a compliment, every time. For 25 years we have been making them flat, and very successfully too. Just like pizza.

Pizzas have made their way into all corners of the world and are appreciated everywhere by rich and poor alike.

It is good that the Saia®PCD2 controller family resembles the pizza not just in shape, but in the esteem in which it is held. The Saia®PCD2 is also economical and can be dressed for every need or taste.

Whether Quattro Stagione, Capriciosa, Principe or Vegetaria: we deliver our products fast, fully loaded and ready to mount on the assembly line. Or you can buy a PCD2 Margherita from stock, and finish equipping it yourself – as the need arises.

With a finely adjusted recipe, better ingredients and outstanding service, we have made our new Saia®PCD2 pizza generation even more attractive. But even now we do not claim to have always the right one for everybody. In the end, nobody wants Bavarian pork knuckle all the time, nor American T-bone steaks, nor French snails (apologies to friends and competitors for these analogies).

I wish you «bon appétit ! » ■

The Cover

Saia®PCD pizza bakery.
We «bake» flat PLCs
from economical to sophisticated.



© Liner Italia International

Saia-Burgess Controls Ltd
Bahnhofstrasse 18
CH-3280 Murten
Switzerland

T +41 26 672 71 11
F +41 26 672 74 99

www.start-controls.com
pcd@saia-burgess.com

Contents

BASIC PRODUCTS

The new Saia®PCD2 generation –a flying start	2
Saia® PCD3 – «Automation's army knife»	4
Saia® PCD Web-Panels –a thriving young product family keeps growing	6
Saia® S-Web-Editor, further progress on a firm foundation	7
Saia®PG5 –new version 2.0	8
Energy measuring technology for alternative sources of energy	9



New generation of Saia®PCD2
2

INFRASTRUCTURE AUTOMATION Saia®DDC Plus

DDC-Plus: the tailor-made room automation solution	10
New, compact controller Saia®PCS1.C4_	11
New functions and IP communication in the KNX/EIB driver	11
Easy efficient coupling to existing or new JCI-N2 bus networks	12
New HEAVAC- and DDC-Suite templates for Saia® S-Web-Editor	12
Radet district heating project – Bucarest Rumania	13

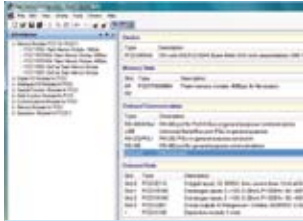

Saia®PG5 –
New version 2.0
8

MACHINE CONTROL

Model of success: Everything completely under control with web technology	14
OEM business: more functionality, higher margins, lower engineering costs	16
Practical experience: CAN implementation	16



New, compact controller Saia®PCS1.C4_
11

TECHNICAL SUPPORT

Optimization of the repairs process	17
FAQ Manager	18
New PC-Software	18
New Firmware	18
New documents since Controls News 9	19

TECHNOLOGY AND TRENDS

Practical test: Accessing Saia®PCD controllers with CGI	20
---	----



Everything completely under control with web technology
14

DIVISION INFO AND REFERENCE APPLICATION

Reorganisation –the next step in company development	22
High investment volume for Controls –a basis for further growth	23
Lötschberg Basic Tunnel includes much Saia®PCD technology	24

LOCAL NEWS

25/26



High investment volume for Controls
23

The new Saia®PCD2 generation – a flying start

A distinctive, low-profile housing is the mark of a Saia® controller. It is a central pillar of our identity. No better or more attractive family of low-profile controllers should ever be available from anyone else. This is the principle that drove us to develop the new generation Saia®PCD2.



From numerous installations and discussions with users, we have learned how to offer customers even more value and functionality for their money. We intend to use this knowledge to consolidate our position in existing markets and penetrate new ones.

The Saia®PCD2.M5 is the first of a new generation. The transition to this new generation from the current one will not be abrupt, but will take several steps to complete. This is in accordance with our company's traditional values: innovative in technology, conservative in business policy.

The Saia®PCD2 portfolio:
Flat as a pizza and just as versatile –
something for every taste.



First step towards the new generation: Saia®PCD2.M5xx

With the Saia®PCD2.M5xx, we have now made available all the technologies and functions of the Saia®PCD3 in a low-profile housing. Simultaneously, we have built in additional functions, such as fast counters, encoder evaluation and an Ethernet switch. Of course, all existing Saia®PCD2 I/O modules can still be used.

I/O modules can now be changed without exposing the CPU board. Alongside a simple screw contact, the separate I/O cover now allows a wide variety of connection systems to be used. Labelling possibilities have also been improved.

It is no longer necessary to plug on the optional display – a control unit with graphical capabilities is already integrated in the housing.

In the medium term, the new PCD2.M5 CPU series will replace existing Saia®PCD2.M15x and M17x devices, especially those with the Ethernet option.

The new CPU is already available for pilot customers and, depending on initial field experience, its unrestricted sales release will probably be announced for early 2008.

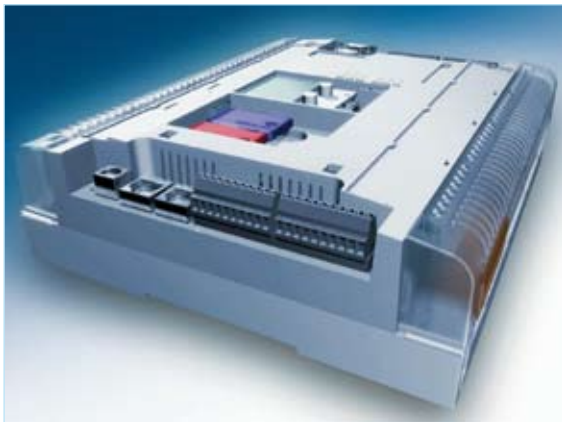

What will follow the Saia®PCD2.M5xxx?

With the Saia®PCD2.M5 we have built a CPU in the same performance class as the Saia®PCD3.M5. Currently, the Saia®PCD2.M48x is our proven high-end PCD2 for system controllers in major infrastructural automation projects or for fast machines. But even this device will be superseded by one with a new generation CPU. Development work has already started on this.

We want to use this new CPU generation not only to address the question of pure CPU power, but also the topic of USB masters, and to push innovation in the HMI field much further forward.

You are right to be interested. We will update you in the next issue of Controls News.

From the new CPU to a new complete system

Looking forward to an advanced total system, even the I/O expansion units of the Saia®PCD2 series will be renewed. Visually, their differentiation from the CPU device will be stronger



The new generation also has new packaging

than before, because they are more strongly oriented towards the features and specific requirements of an I/O system.

For straight CPU expansion, it will in future also be possible to expand a PCD2 system to 1024 I/O points. For local or remote I/O applications, appropriate bus connection technology has been provided.

These expansion units can be connected flush with each other, directly and without cable. ■



Study: Expansion unit for the new Saia®PCD2 generation

Saia®PCD3 – Automation's army knife

Saia®PCD3 controllers have now joined chocolate, clocks and pocket knives as one more typical example of the Swiss quality product.

Nobody surely still needs to extol the benefits of the Swiss army knife: its many different functions and easy manipulation will always give you the upper hand over (almost) any problem – whether the situation is pleasant or difficult.

The ingenious army knife is impressive because of its quality and robustness. Everyone can find just the right type; from the simplest penknife to those with 101 functions, everything is there. The army knife offers almost unlimited possibilities.

Although you won't, of course, find a «Camper», «Huntsman» or «Ranger» in the PCD3 range, you will find an M5020, M5120, M5250, M5350, M5540, M5440, M5540, M6240, M6540, M6440 M6540 and an M2150V6. This complete Saia®PCD3 range of automation devices offers users truly everything their hearts could desire, from the simplest, modular PCD3.M5020 version to the do-it-all PCD3.M6540. And now something new: the powerful, compact M2150V6 versions.

A comparison with the popular army knife and its endless possibilities is obvious. Our satisfied PCD customers would doubtless agree.

Flexible, modular, efficient and robust. Industrial high-tech products from Switzerland, full of original ideas and unlimited functionality – the PCD3 is indeed automation's army knife.



PCD3.M2130V6, the new, compact «multifunctional pocket version» from Saia-Burgess Controls

PCD3.M2130V6 – it has 58 inputs/outputs (including 52 digital ones), enormous user memory, a battery for years of data security, and a slot for an optional communications port – all packed into a small housing just 150 x 140 x 70 mm in size.

The PCD3.M2130V6 is the strong answer for your compact applications.

These compact PCDs offer, without any restriction, the entire functionality of the PCD3 range and so provide a strong



Saia®PCD3.M213xV6

heart and intelligent brain for your automation solutions. Use one once and you will never want to do without it again.

Compact PCDs from Saia® are available for immediate delivery.

PCD3.M6540/M6440 with PROFIBUS DP Master
PCD3.M6540/M6440 CPUs correspond to PCD3.M5540/PCD3.M5440. However, they have in addition an electrically isolated Profibus DP high-speed port with 12 MBit/s. This replaces the S-Net/MPI interface of the PCD3.M5540/M5440.

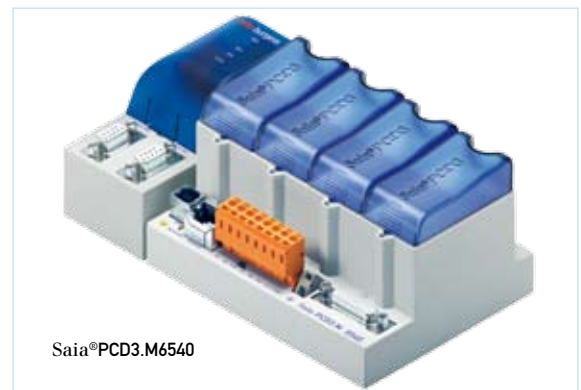

Saia®PCD3.M6540

Data capture, processing, storage, management, forwarding ...

All PCD3.Rxxx flash memory modules for Saia®PCD3 automation devices have now been released for sale. There are no restrictions of any kind.

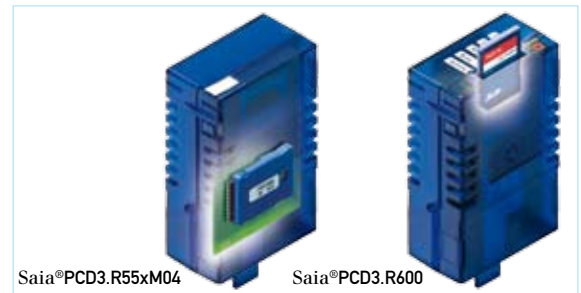

Saia®PCD3.R55xM04

Saia®PCD3.R600

Data capture via local inputs with over 60 types of I/O module and up to 13 serial interfaces per PCD3.

Built-in standard protocols (Profibus, Modbus, EIB, M-Bus...) and many drivers for third-party products make Saia®PCD controllers ideal for use as data concentrators and communications gateways in industrial applications.

Data processing and storage with powerful IL commands and/or convenient graphical Fupla FBoxes.

Data is stored in binary form or in an IT-compatible ASCII format in CSV files. Up to 4 GBytes of industrial SD flash memory modules per Saia®PCD controller are available for data storage.

Secure data management in a stable file system and forwarding via IT-compatible interfaces.

Recorded data is managed in a stable file system that satisfies the high demands of an industrial controller. Integral web and FTP servers in Saia®PCD controllers are used to exchange data directly with higher ranking IT systems. No proprietary communications drivers are necessary. Event-controlled data despatch by email is also possible.

Expandable with up to 8 serial interfaces

All PCD3 automation devices are capable of optional expansion with up to 8 serial interfaces, for which 4 modules will be required. ■

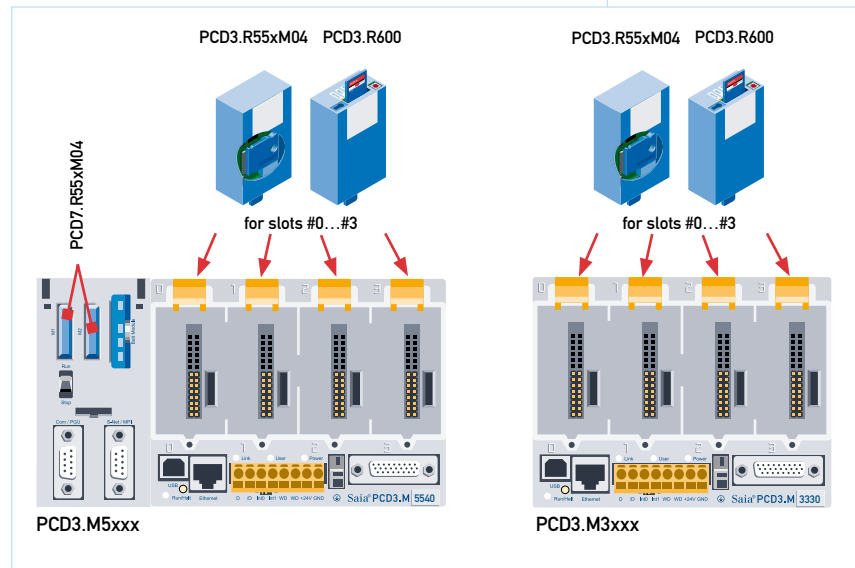

Memory slots for PCD3.M5xxx and PCD3.M3xxx

Overview of modules	
PCD3.F210	RS 422 / RS 485 fixed equipment + 1 free slot for 1 optional PCD7.F1xx interface module
PCD3.F221	RS 232 fixed equipment + 1 free slot for 1 optional PCD7.F1xx interface module
PCD3.F280	Belimo MP-Bus fixed equipment + 1 free slot for 1 optional PCD7.F1xx interface module (in preparation)

- The following PCD7.F1xx interface modules can be inserted in the free slot:
- PCD7.F110 (RS422/485)
 - PCD7.F121 (RS232)
 - PCD7.F130 (CL 20mA)
 - PCD7.F150 (RS485 with electrical isolation)
 - PCD7.F180 (Belimo MP-Bus)



Saia®PCD3 overview – the complete range of multifunctional controllers



		Compact		Basic				Extended			CAN		DP Master		
PCD Classic ¹⁾	PDC3.M	2030V6	2130V6	3020	3120	3230	3330	5340	5440	5540	6240	6340	6440	6540	
		2137V6						5447		5547	6347		6447	6547	
Number of inputs/outputs		38 I/Os		Up to 64 I/Os				Up to 1023 I/Os							
Working memory (RAM) for user program, text/DB		512 Kbytes		128 Kbytes		512 Kbytes		1024 Kbytes							
Backup on-board memory (flash)		512 Kbytes		128 Kbytes		512 Kbytes		1024 Kbytes or optional PCD7.R500 flash card							
File system memory (flash)		1 MByte		Optional from 4 MBytes with PCD3/PCD7.R550M04, up to 4 GBytes with PCD3.R600 & PCD7.R-SD512											
Data protection		Battery		Supercap or optional battery PCD3.R010				Battery							
RS485 on-board for free protocols		Up to 115.2 kBit/s													
Multi-master Profi-S-Bus on-board		(or) up to 187.5 kBit/s				Up to 1.5 Mbit/s			(or) up to 187.5 kBit/s						
RS485/422 interface		No		No		No		Yes		No		No		No	
CAN interface 1 Mbit/s		No		No		No		No		Yes		No		No	
PROFIBUS DP Master 12 Mbit/s		No		No		No		No		No		Yes		Yes	
RS232 interface		1 optional		Up to 8 optional with PCD3.F2xx				1 integral, and up to 8 optional with PCD3.F2xx							
Ethernet 10/100 on-board		No	Yes	No	Yes	No	Yes	Yes	No	Yes	No	Yes	No	Yes	
Integral Web-Server		Yes													
USB 1.1 slave device		Programming interface													

1) Programmable with PG5 Controls Suite

2) Programmable with STEP®7 from Siemens®

News Ticker

Saia®SD memory extension for MB Web-Panels, PCD7.D4 series

Saia®SD cards PCD7.RD4-SD with 256 or 512 MB let you store major web project data locally.

The appropriate interface PCD7.RD4-SD is supplied as an accessory for MB panels.

The following functionalities are available:

- Major web projects can be stored 100 percent on-site.
- Clones of web projects in networks with numerous MB panels.
- Adaptation of the web application without FTP access. Just slot in the new SD card!
- Easy replacement of MB panels with the clone function: configuration, web project and all data are transferred to the new panel.
- Storage of MB panel configuration.
- Storage of larger files, such as unicode fonts.

MB Panels can display all character sets from cyrillic to Chinese

The use of unicode fonts now allows the display of characters not included in western European character sets. They can be called with HTML tags into S-Web Editor projects.

This is done by transferring the appropriate unicode fonts to the MB panel and storing the character strings required in CSV (comma separated values) tables.

Saia®PCD Web-Panels – a thriving young product family keeps growing

Growing functionality, device choice, and control and monitoring power have all helped increase the range of potential uses. This makes our Web-HMI systems even more attractive.

In the shape of the new 3.5 inch web panel, we have developed a small, attractive HMI device whose TFT LCD gives it high picture quality and optimum brilliance.

Since it is almost impossible in a professional setting for devices of this class to have touch control, we have decided to do without a touch membrane, and simultaneously preserve the display's very sharp picture quality.

A special highlight of operation is character entry via an «SMS function». Like a mobile telephone, the numeric keypad can be used for writing text messages. Users will not need pages of instructions or intensive training to make the most of this efficient, innovative solution.

Web and telecommunications technologies are combined in one device. Remaining true to our guideline: we do not invent new standards, but add value to old ones by combination and extension.

New CPU platform for embedded Windows® Web-Panels

With eWin panels, the response in all market segments and customer groups has been very positive. We have seen excellent growth in the quantity of panels sold and the number of customers purchasing them.

Our concept of offering customers a Windows®CE panel that welcomes their own Microsoft.NET applications has been particularly successful and is still unique on the market. While other suppliers only use Windows®CE in the form of a proprietary operating system, we offer Windows®CE as a genuinely open platform.

Ambitious .NET programmers will already have reached the limit of CPU power at some time. Here we offer a fix with the new, significantly faster Celeron CPUs. Since this CPU also runs with Embedded XP, our range instantly becomes more attractive, even for large panels that are typically equipped with Windows®XP.

More power for CE customers, a better price for XP customers - everyone is happy! ■



Saia®PCD

Saia®PCD Web-Panels eXP with CELERON-M CPU



Graphic display

Size & resolution: 10"/12"/15" 800x600 or 1024x768
 Technology: TFT 16.7 million colours
 Control: Resistive touch

CPU

Processor: Intel CELERON-M 1.3 GHz
 Working memory: 512 MByte

Interfaces

Ethernet: 2x 10/100 MBit/s (RJ45)
 Serial interfaces: 1x RS232/485, 2x RS232
 USB: 4x host 2.0
 PS/2: 2x keyboard/mouse
 External monitor: 1x VGA
 Memory cards: 2x CFC slot with 1x CFC memory card (1 or 2 GByte)

Integral server

IIS (web server, FTP server, etc.)
 File server (Samba-compliant)
 S-Web-Connect (routing/communication with PCD controllers)

Operating system, browser & SW platforms

Windows®XP embedded
 Microsoft® Internet Explorer
 Java Runtime Environment
 .NET Framework

Saia®PCD Web-Panel MB 3,5"



Graphic display

Resolution [pixel]: 3.5" QVGA 320 x 240
 Technology: TFT 256 colours
 Keys: Total 29;
 keys + function keys + alphanumeric keypad

Communications connections and protocols

Ethernet (RJ45) 10/100 MBit/s: http direct/ Ether-S-Bus
 RS232/485 (115.2 KBit/s): S-Bus
 USB port: 1x slave
 PS/2 connection: 1 x for keyboard and bar-code reader
 Flash memory for local web server: 4 MB
 SD flash card (256/512 MBytes): option

Saia®S-Web-Editor further progress on a firm foundation

Customer numbers for our Web-Editor continue to grow healthily, reflecting the great benefits this tool brings. Two and a half years after its launch on the market, already over 400 editors are successfully in use, of which more than 80 percent are «advanced editions» with alarm and trend functions.



Macros simplify engineering and save costs

Once edited, system images can be summarized in a macro (system object) and stored in a library for use again later. GIF graphics and data points used are now also stored in that macro with their properties (symbol name, min/max values, display format and unit). When an object is used again, the new symbol selector takes just a few mouse clicks to assign the data points to resources used in the PG5 project. If you apply the same principle in the PLC application and edit the automation objects (FBoxes and Fupla pages) that correspond to the system images, complete installations can simply and efficiently be «clicked together», without costly programming or special knowledge.

Online Alarm History

TID	Alarmtext	Time On	Time Off	ACK	Pg Up
7	Alarm_d7	2007.08.29 01:59:15 PM	--	NAK	
5	Alarm_d5	2007.08.29 01:59:10 PM	2007.08.29 01:59:10 PM	NAK	
2	Alarm_d2	2007.08.29 01:59:08 PM	--	NAK	
2	Alarm_d2	2007.08.29 01:59:07 PM	2007.08.29 01:59:07 PM	NAK	
7	Alarm_d7	2007.08.28 04:22:37 PM	2007.08.29 01:59:15 PM	NAK	
3	Alarm_d3	2007.08.24 08:20:54 AM	--	NAK	
2	Alarm_d2	2007.08.24 08:20:54 AM	2007.08.29 01:59:06 PM	NAK	
4	Alarm_d4	2007.08.08 10:11:02 AM	--	NAK	
1	Alarm_d1	2007.08.08 10:11:02 AM	--	NAK	

Total Entries:

Standard alarm macro from Saia-Burgess Controls

Standard alarm and trend macros – flexible in design and function

Alarm and trend functions are now supported throughout all Saia®Web-Panels and PCD controllers with an integral web server. The newly available Web-Editor macros and Fupla FBoxes make these functions quick and easy to configure. Micro-browser panels can now also display these macros in ¼ VGA resolution.

Programmers can adapt the layout and functionality of standard macros to the application and to the needs of users.

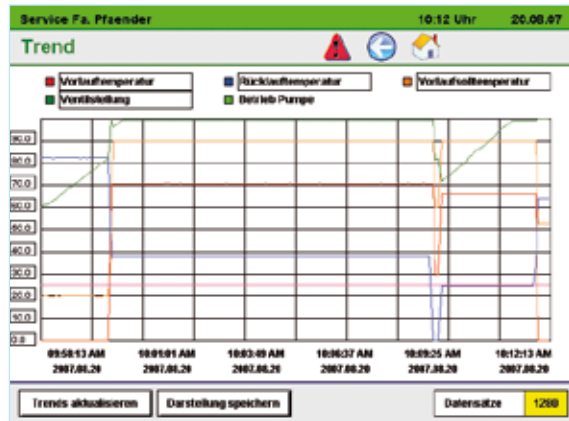

Trend macro adapted to the needs of users

For example, the arrangement, size and colour of buttons or other elements are freely selectable.

An example from practice

The Pfänder company in Baden-Württemberg, Germany makes good use of the S-Web HMI concept in building automation. For smaller installations, our WinCE web panels are now used in place of standard PC-based building management technology. This not only does away with the high cost of software licences, but also considerably reduces engineering costs by re-using the company's own standard system macros and the Fupla programs that go with them. The use of innovative web technologies in association with high value, attractive touch-control panels has made the Pfänder range stand out clearly from its rivals. ■

Service Fa. Pfänder 10:12 Uhr 20.08.07

Alarmhistorie

Nr.	Alarmtext	Gekommen	Gegangen	Status
60	RL12 Kuehler Rueckluftuehler	2007.08.20 10:11:59 AM	--	NAK
67	RL12 Erhitzer Vorluftuehler	2007.08.20 10:11:59 AM	--	NAK
65	Vorlufttemperaturuehler	2007.08.20 10:11:59 AM	--	NAK
62	Vorlufttemperaturuehler	2007.08.20 10:11:45 AM	--	NAK
64	RL12 Raumtemperaturuehler	2007.08.20 10:11:47 AM	--	NAK
62	Zulufttemperaturuehler	2007.08.20 10:11:47 AM	--	NAK
67	Raumtemperaturuehler	2007.08.20 10:11:47 AM	--	NAK
2	Aussenlufttemperaturuehler	2007.08.20 10:09:59 AM	2007.08.20 10:09:11 AM	NAK
48	RL12 Erhitzer Rueckluftuehler	2007.08.20 10:08:57 AM	2007.08.20 10:09:10 AM	NAK
23	Ruecklufttemperaturuehler	2007.08.20 10:08:57 AM	2007.08.20 10:09:10 AM	NAK
16	Ruecklufttemperaturuehler	2007.08.20 10:08:57 AM	2007.08.20 10:09:10 AM	NAK
13	Ruecklufttemperaturuehler	2007.08.20 10:08:57 AM	2007.08.20 10:09:10 AM	NAK
60	RL12 Kuehler Rueckluftuehler	2007.08.20 09:57:07 AM	2007.08.20 10:00:07 AM	NAK
67	RL12 Erhitzer Vorluftuehler	2007.08.20 09:57:07 AM	2007.08.20 10:00:07 AM	NAK
15	Vorlufttemperaturuehler	2007.08.20 09:57:07 AM	2007.08.20 10:00:07 AM	NAK
12	Vorlufttemperaturuehler	2007.08.20 09:57:07 AM	2007.08.20 10:00:07 AM	NAK
44	RL12 Raumtemperaturuehler	2007.08.20 09:57:06 AM	2007.08.20 10:00:06 AM	NAK
22	Zulufttemperaturuehler	2007.08.20 09:57:06 AM	2007.08.20 10:00:06 AM	NAK
17	Raumtemperaturuehler	2007.08.20 09:57:06 AM	2007.08.20 10:00:06 AM	NAK
61	Drucktemperaturuehler	2007.08.20 09:55:11 AM	--	NAK

Adapted alarm macro from the company Pfänder

Saia®PG5 – new version V 2.0

The new PG5 version 2.0 will be here soon. This new release brings many improvements and fresh features.

New Device Configurator

The new configuration program is the first difference people will notice. In version 1.4 it was necessary to click on several different hard-wired pages to define the necessary settings. Now one just starts up the «Device Configurator» containing all the device settings, such as S-Bus settings, memory allocation, password, TCP/IP address, etc..

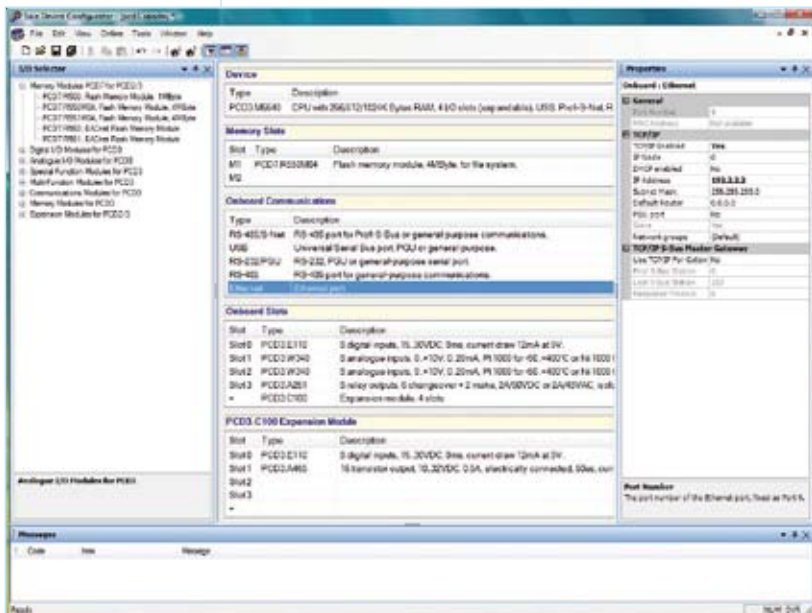

Configuring a PCD2.M5540 with the new Device Configurator

Another innovation concerns I/O module configuration. Users can exploit the latest firmware functions of the PCD2 and PCD3 families, and leave I/O addressing to the operating system. For example, in the case of an analogue input module, users just need to specify the registers to which values will be transferred, and any necessary conversion is done at the same time. This saves having to position an FBox or call an IL program just to read an analogue input. Outputs are handled in the same way.

With the integral label editor, people can create and print label strips for I/O modules with just a few mouse clicks.

The «Device Configurator» also offers the possibility of printing out the complete device configuration as documentation.

Symbol Editor

The new «Symbol Editor» also includes some innovations. For example, attributes can be assigned to symbols. If the user assigns symbols to be exchanged with other Saia®PCDs via a network as «network symbols», they can be quickly found using search functions or filters.

Editors

The Fupla and Graftec editors can now have several files open at a time. For users, this means simultaneous editing of multiple files and their debugging. Laboriously opening and closing files is a thing of the past. Another improvement concerns working with FBox libraries. Users can now choose whether a library should remain as before in the PG5 directory, or whether it should now be copied into the Project directory. If libraries are copied to the Project directory, they will also be saved with the project when it is backed up. With Graftec, users can bring frequently used sequences together as a template that can be inserted into programs with a mouse click.

Other features

There are, of course, other additions both small and large, which space considerations prevent us from listing here. They include, among others, the trend function in the Watch Window and the revised GUI. However, the new version also includes investment for the future. Many background components have been completely revised or rewritten. New interfaces, particularly for the Symbol Editor, improve the interplay between PG5 and other tools like Saia®Web-Editor. New IL commands and structures (e.g. temporary data), which the new PCD versions support, simplify programming and organize work with Saia®PCD even more efficiently. ■

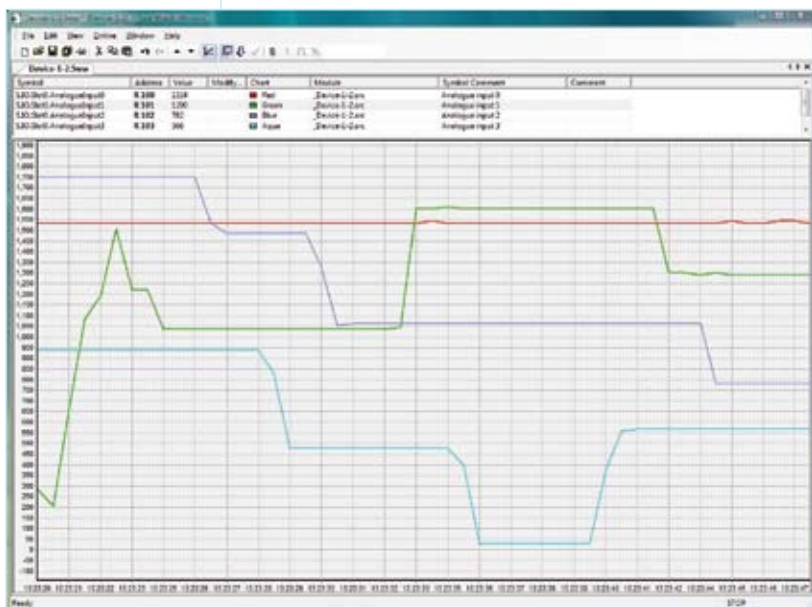

New trend function in the Watch Window simplifies machine or installation commissioning.

Energy measuring technology «made in Switzerland» – Swiss precision in energy measuring technology for alternative sources of energy

Compact and exact – Energy meters from Saia-Burgess Controls

Alternative sources of energy are gaining ground. A steadily rising number of public, commercial, and even private investors are staking money on the efficiency of ambient heat from air, earth and water. Currently, the heat pump is experiencing a boom. Energy saving, «passive» houses in particular have made them a standard part of house technology. The Fraunhof based Institute for Solar Energy Systems (ISE) has started a four-year field trial in collaboration with various manufacturers and power suppliers on the subject of heat pumps in low energy houses. This project, requested by the Federal Ministry of Trade and Commerce, is to clarify how efficient heat pumps are in buildings of the current standard, and whether they offer a sustainable alternative to fossil energy carriers. By summer 2010, researchers from the Fraunhof Institute will have measured in field trials a total of 140 heat pumps from seven manufacturers in private houses over two heating periods and one summer each. Overall system behaviour is logged minute by minute: main temperatures, flow rates, heat currents and, of course, the electricity consumed by accessory drives.

Exact values measured by reliable meters

When carrying out any successful trial, the exact measurement of values is fundamental to every assessment. In the energy field, the Fraunhof Institute relies on the years of experience of Saia-Burgess Controls. The power consumption of electric accessory drives for the heat pumps must be broken down and recorded. This is done by using a Saia-Burgess Controls single-phase alternating current meter for 32 A, while their three-phase meter is used for 65 A. The particular advantage of these meters is their narrow construction. Prime importance in meter choice was also given to their precision class and certification or approval. Consequently, meters from Saia-Burgess Controls are also approved for officially calibrated measurements.

METAS – the national institute for metrology



The Federal Office of Metrology (METAS) produces and mediates internationally agreed and recognized units of measurement of the required precision. It oversees the use of means of measurement in the fields of commerce, transport, public safety, health and the environment. METAS monitors the implementation of statutory requirements by the cantons and by official calibration centres. The Federal Law on Metrology forms the legal basis of its activities. METAS provides a variety of services to society, the economy and research. METAS directs its business towards enabling customers to measure, test or assess conformity as correctly and precisely as necessary.



New Control Components Catalogue Order now free of charge!

Control Components: alternating and three-phase meters, timers, monitoring relays, electromechanical and electronic counters.

The new Control Components catalogue is available in four languages (English, German, French and Italian). Order your personal copy of the CC catalogue free of charge: send an email with your name and address to us at: cc_katalog@saia-burgess.com.



MID – always state-of-the-art

Following certification by Switzerland's Federal Office of Metrology (METAS), Saia-Burgess Controls has been manufacturing energy meters that comply with Europe's new Measuring Instrument Directive (MID) since August 2007, making it one of the first manufacturers to have devices that meet new European requirements. MID is one of the directives issued by the European Parliament. It specifies not only basic requirements but also some that are specific to measuring instruments for certain device groups. The manufacturer is assigned responsibility for bringing measuring instruments into circulation for the first time. With the introduction of the MID, initial calibration in officially approved test centres will be replaced by manufacturers' declarations of conformity. Saia-Burgess Controls is an experienced partner for alternating and three-phase meters and increasingly directs its attention towards new technologies in the field of renewable energy. ■

INFRASTRUCTURE AUTOMATION

DDC.Plus: the tailor-made room automation solution

With its new PCD7.L6xx series of products, Saia-Burgess Controls has brought to market a flexible solution for integrated room automation. A basic controller is combined with extension modules for light and shade to meet almost all the demands placed on a modern room automation solution.

Operation is via separate room control devices in analogue or digital technology. For ease of integration into building infrastructure, basic controllers are provided with Saia® Serial S-Net or LONWORKS®-communication.

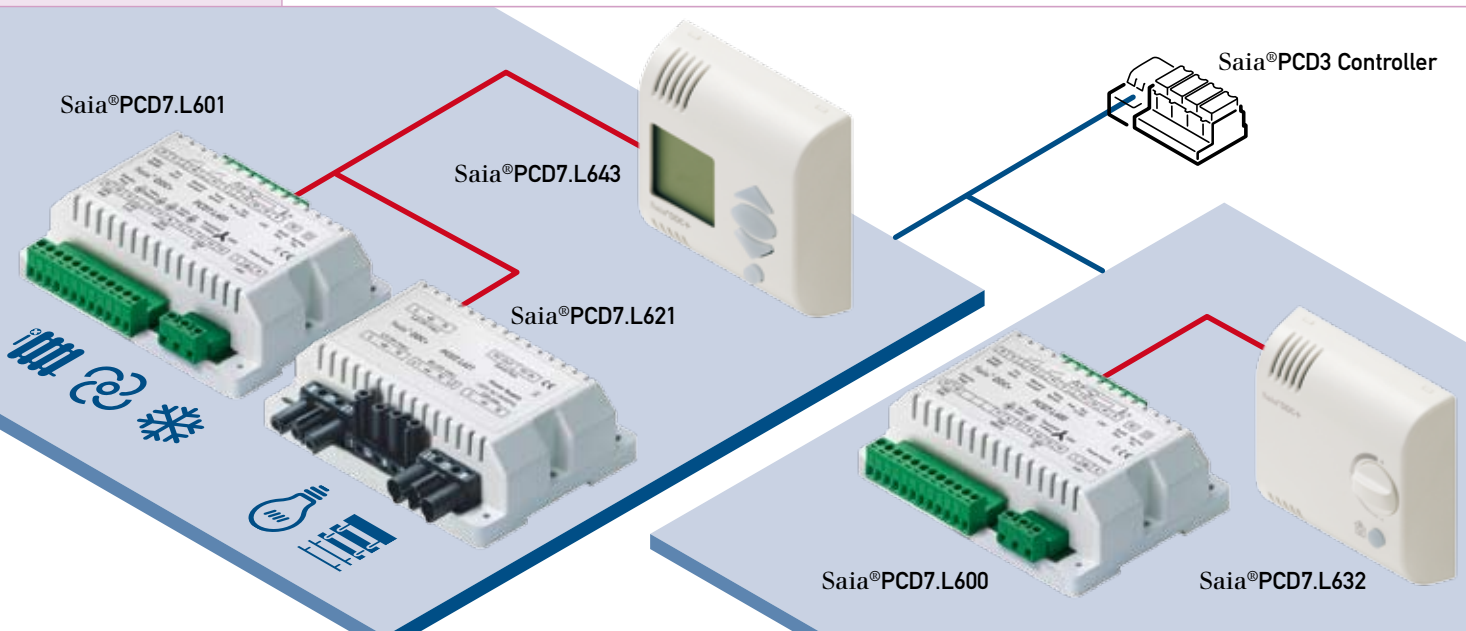

Integrated solution for measurement, control and electrical facilities

System characteristics

- Operating voltage 230 V or 24 V
- Integrated load relay for triggering 3-stage ventilator (fan coil applications)
- Valve triggering for heating and cooling with PWM, 3-point or 0-10 V
- Operating modes: comfort, standby, non-use, frost protection
- Selectable control modes: autonomous or as RIO
- Dynamic changeover from master / slave function
- LONMARK® with fan coil function, profile 8020

Basic controller with Serial S-Net

Modules with a Saia® Serial S-Net interface offer users a high degree of comfort and flexibility. This starts with good commissioning support, including automatic recognition of communications speed and intelligent bus addressing. Automatic monitoring of the base setting allows parameters to be set within seconds, not only during commissioning but also for service.

Already integrated within the application software are 10 user programs for installations with fan coil devices, variable volume flow systems and radiator/cool ceiling combinations that can be activated by the integrator setting parameters. For special applications, processing of the user program may also take place in a PCD. If so, parameters will be set to disconnect internal controller function and outputs will be driven directly in RIO operating mode. All parameter settings will be retained for years, even in the absence of any line voltage.

Room controllers support a flexible master/slave system. This allows applications in which one room controller is configured as the master and others as slaves. In such cases, the slave will follow the master's setpoint. Operating modes can be switched during runtime via a connected Saia® automation system. This is frequently used for automating variable conference room in particular.

Basic controller with LONWORKS® interface

Basic controllers with LONWORKS® communication meet fan coil function profile 8020. These devices will therefore fit easily into any building automation based on LONWORKS®. The standardized functionality of LONWORKS® guarantees interoperability between different systems.

Room control units

Operation of the controllers is via analogue or digital room control units. Analogue room control units are connected to the controller via input terminals. By using standardized input signals and temperature sensors, it is also possible to utilize vendor-neutral room control units with the controller.

Control units with a digital interface are connected to the controller through prefabricated cable and have operator keys and a display function. For special building areas, mobile remote control units are used with infrared or a wireless interface. When digital control units are used, the controller's analogue inputs can serve to connect other free data points. These inputs will then be read directly via the PCS/PCD master.

Expansion modules for lighting and shade

To integrate lighting and shade facilities within room automation, one basic controller can have up to 3 expansion modules connected with max. 4 lighting rows and max. 4 window-blind drives. Operation is via a digital or mobile room control unit, or directly via the PCS/PCD master.

This comprehensive portfolio of controllers, expansion modules and room control units allows flexible room automation solutions to be produced and commissioned in comfort. ■

New, compact controller Saia®PCS1.C4_

Our new product, the PCS1.C4, is the logical extension to our PCS range of compact controllers. With just 19 data points, the PCS1.C4 is the smallest controller in the PCS range and is offered at a very attractive price.

The new PCS1.C42x series controllers from Saia-Burgess Controls offer compact, cost-efficient solutions that quickly and easily satisfy the requirements of heating, ventilation or air-conditioning engineering. With 19 data points (analogue or digital) the PCS1.C42x is also perfectly adapted to use for control tasks in compact devices.

Should the control tasks demanded become more complex, the outstanding networkability of controllers from this series allows them to be expanded as necessary.

Every PCS1 can be optionally equipped with an analogue, ISDN or GSM modem. Only the cable or GSM antenna is connected to the controller itself. In this way, all the main telecommunications services will be available, including tele-maintenance, remote diagnosis, and sending/receiving SMS messages. ■

Maximum functionality in minimum space

- Integral or separate graphic display with single-knob control
- Integral manual/emergency control and coupler level
- Compact size: 195x150x60 (WxHxD)
- Plug-in spring terminals with cover
- Large memory for history data
- 19 data points directly on device, expandable via network



New functions and IP communication in the KNX / EIB driver

Migration from EIB to the KNX standard, combined with function requirements for larger KNX/EIB applications, have made an addition necessary to the existing driver family.

The new driver now also supports the new generation of serial BCU2 couplers, which work much more powerfully on the RS232 interface than the older BCU1 generation, due to the adapted protocol. This allows installations whose operation fails to meet performance requirements to be upgraded or converted quickly and economically.

With the new EIBnet interface even powerful KNX/EIB applications are achievable. This interface allows the serial connection between a Saia® automation station and a KNX/EIB coupler to be replaced with a direct Ethernet/IP connection. The new driver module lets the connection be established via IP. Data can be exchanged with EIB nodes in the usual way via send/receive blocks.

With various possibilities for physical connection and the new driver library, there are no limits to the integration of Saia® automation stations in the KNX/EIB network environment. ■

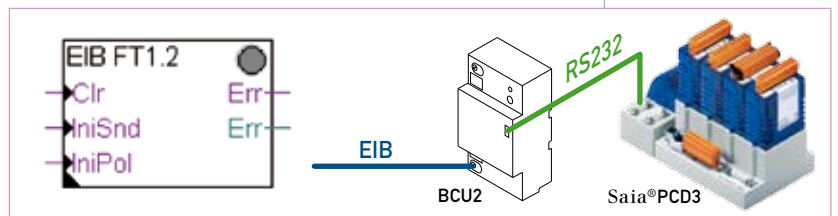

Example with BCU2 KNX/EIB coupler

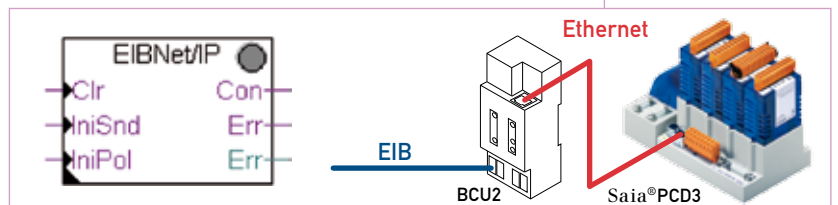

Example with EIBnet coupler

Product Information

BACnet® certification

With effect from autumn 2007, new BTF software (BTF = BACnet® test framework) from the company MBS now allows automated testing of automation stations with the full functional range of a B-BC (BACnet® building controller). This means that all B-BC devices listed in Europe must subject themselves to this new test for certification.

Saia-Burgess Controls has already applied to an accredited testing laboratory for the automated test and will have completed testing on PCD systems in time for Light & Building 2008. PCD systems will receive a certificate from what is currently the only accredited testing laboratory in the world (WSPLab in Stuttgart/Germany).



Easy, efficient integration of Saia® PCS/PCD systems to existing or new JCI – N2 bus networks

Whether you need to replace JCI system components in old installations, or couple Saia® with JCI automation systems in new installations, this new driver library gives you an easy way to do it.

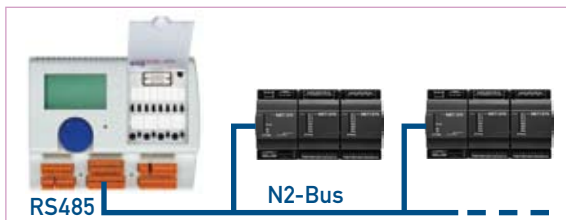

Integration into a JCI – N2 bus network can take place across any RS 485 interface, which is included as standard in every PCD/PCS. After driver configuration, the Saia® automation system will behave like a normal N2 bus station for the exchange of system-specific data.

The driver allows the Saia® system to behave either as a master or as a slave in the network. In master mode for example, JCI expansion modules type XT-910x or XP-910x can be coupled to it and any connected data points read or written to directly. This variant might be used, for example, when web-

based user prompting is to be added to the automation level. In slave mode, the Saia® system will behave like an appropriate JCI extension module.

The current spectrum of use for the driver shows a clear tendency towards old installations, where JCI systems are replaced or extended with Saia® automation systems. ■

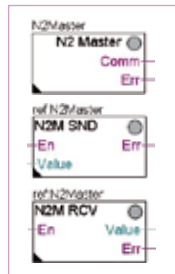

New HEAVAC and DDC-Suite templates for Saia® S-Web-Editor

Efficient engineering for web-based user prompting with ready-made objects for HEAVAC and sanitary applications. The use of S-Web templates will make editing web-based user prompting for HEAVAC and sanitary installations significantly more efficient. All templates support the parameter setting functionalities of the HEAVAC and DDC-Suite library. Templates comprise three core elements:

Graphical objects
for creating system graphics.



System templates
complete system templates that match DDC-Suite and are based on standard application programs.

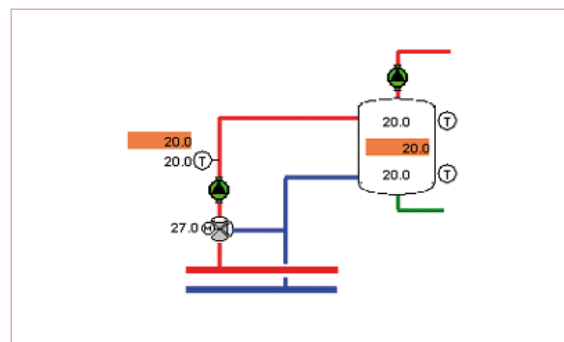

Parameter adjust windows
that match each graphical object, for the adjustment of system-specific parameters.

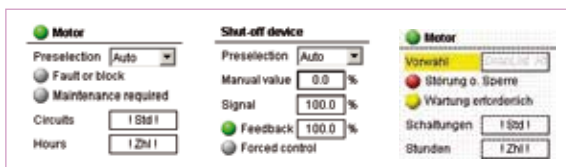

The graphical resolution of these templates has been optimized for use with micro-browser panels at a resolution of 320x240 pixels. With this resolution, the templates can also be used on all other panels.

With just one, simple assignment function, the graphical elements of an object – or complete installation – are connected with data point values in the automation system. All additional information, such as data format or limiting values, are edited automatically. ■

Characteristics

- Templates match the HEAVAC / and DDC-Suite library
- Easy symbol and resource assignment with group addressing
- All templates are adaptable to individual usage
- Templates are available in 2D or 3D optical versions
- Considerable reduction in engineering time for S-Web applications

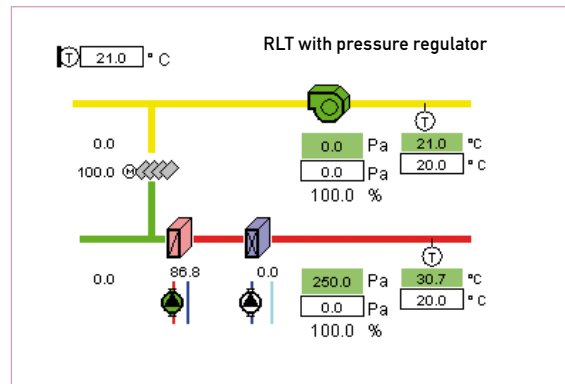
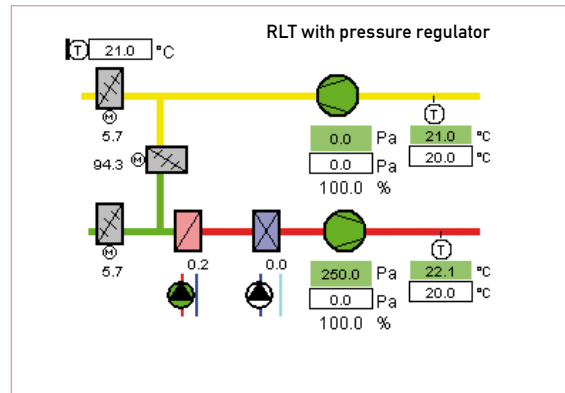

System examples with 2D and 3D graphical templates

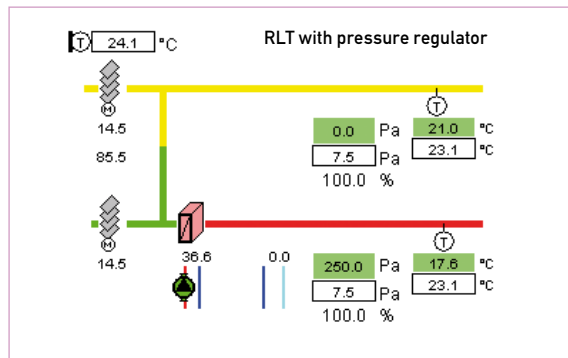

Radet district heating project – Bucarest Rumania

To improve quality of life, Bucarest has decided to equip existing but still largely undeveloped prefabricated slab buildings (approx. 2 million residents) with heating energy.

For the purposes of this development, the entire region was divided into approx. 400 areas and equipped with district heating transformer stations. Each of the transformer stations must supply 2–3 residential units with energy for heating and hot water, all controlled and regulated with Saia®PCD3.M5540 systems. The transformer stations draw primary energy in the form of hot water from three gas-fired power plants located nearby. To monitor system control, installations can be accessed and influenced at all times via modem.

The Swiss company Fela Planning Ltd tendered for the entire project with Saia®PCD3 system components and was awarded the contract to supply both the open and closed loop controller parts, despite lower offers. The decisive arguments in their favour were the power of PCD3 architecture, its expandability, and the possibility of using M-Bus to integrate additional tasks (e.g. energy cost billing).

The customer is very satisfied with the way delivery has progressed, and with initial results from installations already in operation. Thanks to this good reference, the customer would like to continue working with Saia®PCD systems in future. ■

Graphics of a district heating station



Project volume

> 1 Mio. CHF
 for 460 stations
 Saia®PCD3.M5540 with
 Saia®PCD3.C100, PCD3.W315,
 PCD3.W305, PCD3.W605,
 PCD3.E610, PCD3.A220

Model for success: Everything completely under control with web technology

The communications world has experienced enormous change in recent years: mobile telephones and internet are widespread and have become part of everyday life. In industrial automation, web technology opens up completely new concepts and possibilities that trickle down into the business models of our customers. Hansa is a company that has consistently backed the openness of this technology and used it to generate profit.



The new Saia®PCD2.M5540 in a central air conditioning unit: enough power for the application. web technology, BACnet®, and field-bus interfaces

Deutsche Telekom as a motor for innovation

No less than ten years ago, Deutsche Telekom Immobilien GmbH (DeTeI) used a central management system with database structured software (BuES, Building and Energy Management System) for the central control and monitoring of technical equipment present in existing buildings. At the time, Saia-Burgess responded to the requirements defined and supplied several thousand BuES data concentrators based on the PCD2.



BuES data concentrator for DeTeI: Several thousand complete switch cabinets were supplied by Saia-Burgess Controls in the mid nineties

A large part of Hansa's success is based on years of experience working with DeTeI, who at present operate more than 5000 Hansa air conditioners to cool down rooms with a high thermal load. Most of these devices are linked to BuES (PCD2) systems for the purpose of capturing operational data.

In the early nineties, when there were no widely accepted standards for the BuES linking of diverse, proprietary automation systems, DeTeI defined and pushed through its own protocol. Connection of data concentrators to the management station was via the TCP/IP protocol, or optionally via GSM or analogue modem. It was also crucial for DeTeI that data concentrators should have the greatest possible flexibility in supporting a wide range of field bus protocols, such as EIB, LON, M-Bus, etc. Even then, all this was an integral part of the Saia®PCD standard.

Saia®PCD controls the climate – right for every situation

In the course of these DeTeI projects, Hansa quickly realized that Saia's freely programmable control technology offered powerful advantages over dedicated DDC systems. The same system can just as easily be used for their small, high-volume, slim-line devices as for their large, networked, climate systems. For Hansa, Saia®PCD satisfies the demands not only of their price-sensitive volume business, but also their complex, individual project business.

People have very exacting sensitivities and requirements for room climate, depending on the widest variety of tasks and activities. Here Hansa intends to leave nothing to chance. The single room controller is therefore an integral part of Hansa's overall solution. Fortunately, Saia® has a broad, complete system catalogue with a full range of standard products for every type of application – indispensable for the strict demands that Hansa makes on itself.

Hansa concentrates completely on web technology

If DeTeI were to invite tenders today for the same project as in the nineties, the project specification would probably look much more modest in scope than then. Two concepts – web technology and BACnet® - cover much of what, even recently, had to be comprehensively specified for proprietary protocols. Both terms have also become standard with Hansa.

Hansa has long since turned its back on individual project engineering – with its laborious links to higher ranking management systems, specific user interfaces, necessary interface definitions, etc. – and now concentrates completely on web technology. Thanks to web technology, every step can now be modularized and standardized. Individual Hansa air conditioners already contain the building management technology required for controlling and operating the individual unit. The user interface is stored in the form of web visualization in the web servers of the Saia®PCD controller. All that is then needed for overriding building management technology is to link up with the separate controllers of the air conditioning units. This means significant economies in project planning and commissioning. It goes without saying

that this web technology approach automatically includes functions like teleservice and maintenance – even from Hansa's headquarters.



Windows® CE 10" web panel:
Visualization is stored in the controllers' web servers.

BACnet – the measure of many things in building automation

Air conditioners are always part of the technical infrastructure equipment in buildings. With large projects, the ability to link into a central building management system is a must. BACnet® (Building Automation Control Network) has established itself as the international communications standard at this management level.

Saia®PCD controllers also talk BACnet®, so Hansa too can unequivocally handle this challenge. This shows particularly well that Saia® - as a reliable, flexible partner for automation – is able to keep step even with highly innovative customers.

Pizza PLC as a major plus

Hansa's Slim-Line and Smart systems are extremely compact. Any available volume must serve one purpose above all: effective and energy efficient air treatment. The controller is only the means to this objective – it will not be given any more space. The flat shape of the PCD1 and PCD2 has proved highly advantageous here. Despite the tightest space conditions, the



Space is very tight in the Slim-Line: The flat shape of the Saia®PCD1 is a perfect fit. On-site control is via the Saia®PDC7.D231 control terminal. Even in the small PCD1, a web server for web visualization is standard.



Central air-conditioning unit from Hansa, with a Windows®CE 10" web panel from Saia® as building management technology. All the air conditioners in one system are linked to the central unit via the web interface.



Central communications cabinet at HANSA's headquarters:
Web access to every application in the field.

entire controller technology is integrated directly inside the air conditioner. This allows Hansa to avoid separate control box solutions – another plus in this tough competition.

Hansa on course for growth

Rigorous modularity all the way to the building management level combined with a firm commitment to innovation has placed Hansa on a steady course for growth. The whole world has long since been conquered: apart from Europe, major projects have been implemented in the USA and the Middle East, and initial projects in the Far East. Web technology is the right solution at the right time – even for today's projects with Deutsche Telekom. ■

Slim-Line from Hansa:

Thousands of these slim air conditioners are in use with Deutsche Telekom.



A dream becomes reality for production machine builders – more functionality, higher margins, lower engineering costs

For one major European manufacturer of industrial air-conditioning cabinets a dream has come true, both technically and economically.

He can cut overhead costs, because in future he no longer needs two programming systems for the same applications. And he has a quieter life, because he no longer has to worry about technical problems, nor about the product lifecycle of his own controller hardware.



Functionally too limited and too troublesome. High product care costs.



Too expensive and will not fit in small devices. Base technology possessed by all.

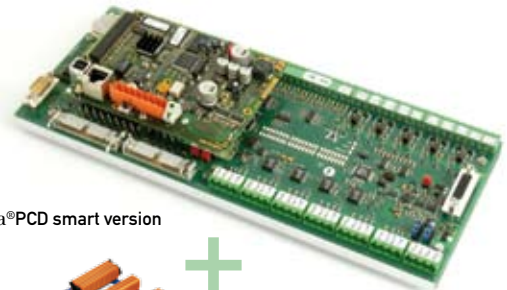

Saia®PCD smart version



Extension:
Saia®PCD standard modules

All this, because in future he can use just one very economical, technically innovative base unit (Smart Saia®PCD5) for all his machines, instead of two completely different series. This will allow – at no great cost or risk – a new generation of machines to emerge with a guaranteed future, because the Smart.PCD5 is compatible in construction and connection technology with his own existing controller.

Even the manufacturer's old STEP®7 applications programs can be transferred directly to Saia®PCD5 – no rewrites, no project risks.

A financial analysis of the manufacturer's range of air-conditioning cabinets will show that margins are significantly better than they were, thanks to lower overhead costs and higher performance. This leaves the company well prepared even for a period of economic recession. ■

Saia®PCD in production machines = More pleasure in business.

Practical experience: CAN implementation

In the last issue of Controls News, we described in this section how openly and transparently CAN has been integrated into the Saia®PCD3. This scrupulous approach to implementation came naturally, because of the traditional communicative character of Saia®PCD culture.

We recently experienced how this can be quite different with other, highly regarded controller manufacturers, when a machine application required us to connect the Yaskawa drive shown here to a Saia®PCD5 via CAN.

Naturally, we wanted to read the protocol from the PLC program's code (as per IEC 1131) to reprogram it in Saia®PG5. Unfortunately an error was reported, because the protocol in this PLC has been written in «C» and the code belongs to the controller manufacturer. Therefore, the machine builder cannot even change components on his drive branch without the (paid) services of the controller manufacturer. If Yaskawa

changes anything in the behaviour of their CAN communication, a beautiful, triangular relationship will begin. Things become interesting when the controller manufacturer also wants to supply the drive. Then all it takes is for him to feel less cooperative.

Of course, the machine builder can become irate about it, but that will not be much use. He no longer has control of his own system. And all that just because CAN is not open to the PLC programmer... ■



CAN do – but how?

TECHNICAL SUPPORT

Optimization of the repairs process

Important changes in technology, product portfolio and customer behaviour have presented the repairs service with new challenges. In recent months, therefore, we have analyzed the entire repairs process from customer to factory and back to the customer. Various innovations have been implemented. Our aim has been to continue providing you with a reliable, prompt repairs service now and in future.



Apart from the introduction of new tools and resources, cooperation has also been optimized between sales companies and the factory in Murten. This has resulted in a clear reduction in processing times.

One of the innovations concerns the introduction of a form for returned goods (available for downloading under www.sbc-support.ch in folder: «Repair service»).

Form for returned goods

To ensure that returned goods are dealt with reliably, we need accurate information about the reason for their return

and the service required. Please therefore enclose the new forms, duly completed, whenever you return any goods.

When goods are returned to us with the «standard repair» option, or if no more explicit details are given, we reserve the right to exchange rather than repair them. This allows us to respond better to fluctuations in demand on the repairs service and ensure speedy processing. If you need a repair report, for whatever reason, please select the appropriate option on the returned goods form.

For the purposes of our quality assurance, it does not matter whether a module is repaired or exchanged. We consider it essential to maintain the reputation of PLC technology with its characteristic reliability. We therefore analyse all modules that, to save time, have been exchanged.

FORM FOR RETURNED GOODS
Bitte füllen Sie das Formular für jedes zu retournierte Bauteil aus.

<p>Billing address:</p> <p>Company: _____</p> <p>Street and number: _____</p> <p>Post code and town: _____</p> <p>Country: _____</p>	<p>Shipping address (if different):</p> <p>Company: _____</p> <p>Street and number: _____</p> <p>Post code and town: _____</p> <p>Country: _____</p>
<p>Contact person:</p> <p>Surname, first name: _____</p> <p>Department: _____</p> <p>Telephone No: _____</p> <p>E-mail address: _____</p>	<p>Returned module:</p> <p>Device type: _____ <small>(e.g. PCC01-01-23)</small></p> <p>Production date: _____ <small>(e.g. 05/04)</small></p> <p>Serial number: _____ <small>(if available)</small></p> <p>Reference: _____ <small>(SBC ref.)</small></p>

Detailed description of the problem / fault description:

Symptoms: _____

Environment / Application / Remarks:

Requested service (choose only one!)

Standard repair: This is the default and applies the cheapest option. The only remuneration will be the shipping costs. ASB will then be asked to exchange the module, a repair report is available for delivery. The original customer has to provide a note to other staff members, in those cases where instructions can only be obtained after the normal path.

Option Repair report required: This is the right choice if a repair report is required by all means. To ensure this service is available to all of the modules in the factory or other test sites, the damaged module can be repaired and the option is available through the modules that are returned by default, even if they are other variants. Please describe the reason in detail and attach to the customer.

Other arrangement: Please specify the return reason under "Remarks" and that your return is made as a favor by request.

Date and signature

Date: _____ Signature: _____

Saia-Burgess Controls AG, 24_002_02_Returned_Goods_E_V1 March 2017

Introduction of boundary scan technology

A technical innovation has been made with the introduction of boundary scan technology.

This technology comprises an on-board bus that passes through the CPU's high value chips, allowing some costly software not only quickly to check the connections, but also to read valuable information from the chips. Alongside fast, in-depth diagnosis, this technology also enhances the reliability of the repairs service, since CPU parts can now be tested that were not accessible with traditional methods. ■

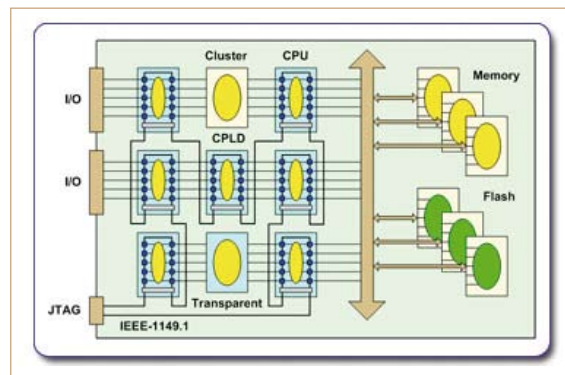

News Ticker

PGU port of PCD3.M5xxx/M6xxx does not work reliably with firmware version 039

Use of firmware version 039 with PCD3.M5xxx/M6xxx CPUs may stop their PGU ports from working. PCD3.M3xxx CPUs are not affected because they do not have a PGU port.

Correction: Use the USB port to download a new firmware version (version 03C or later), available on the PCD3.Mxxxx page of www.sbc-support.ch.

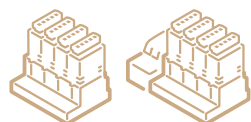

Corruption of analogue values in Fupla with PG5 1.4.200

When online, some people using the Fupla Editor in PG5 1.4.200 may observe corruption of analogue values read with FBoxes.

To correct this error, a patch for PG5 1.4.200 is available on the PG5 page of www.sbc-support.ch.

FAQ Manager

It is now possible to view approx. 650 FAQs in the FAQ Manager under www.sbc-support.ch/faq. A few examples of useful FAQs are described below:

Web page values not updated with Java Virtual Machine 6

With Sun Java Virtual Machine 6 (or 1.6.0), new standard settings of the virtual machine may result in web pages created with the Web-Editor not being updated in the expected way. Solution: Modification of a caching option according to FAQ 100708.

Analysing S-Bus communication with Tracewin

The PG5 folder contains the diagnostic tool Tracewin.exe. This tool can be used to monitor the S-Bus communication of software products based on the scomm.dll communications library. It is particularly useful in association with PG5 and

Analyzing S-Bus communication of PG5 by using Tracewin
FAQ #100268

The tool `Tracewin.exe` is a small executable that records the communication between PG5 and the S-Bus communication driver. It is very useful in order to analyze the communication between PG5 and the PCD's. Since it logs the information of the `SCOMM.DLL`, it may also be used for recording S-Bus traffic of the SAIA OPC server or any other software using the SAIA S-Bus driver.

Opening Tracewin
The tool Tracewin is installed in the installation folder of PG5 (default location: C:\Program Files\SAIA-Burgess\PG5_3\Tracewin.exe). It is to be called by double clicking it.

As soon it is called, the following window will be opened:

the OPC server. FAQ 100268 explains how you can configure and use Tracewin.

New designations for firmware versions of OS NT based products

Instead of a three-digit version number with suffixes like \$ or #, the firmware versions of OS NT based products will in future have the format: a.bb.cc. FAQ 100741 explains the new concept, including information about displaying new firmware versions in old PG5 versions. ■

New firmware version names for Saia-NT systems (a.bb.cc)
FAQ #100741

In order to simplify the interpretation of firmware versions and to avoid confusion regarding implemented features and bug fixes in different firmware versions, a new firmware version format for Saia-NT based systems will be introduced.

Arguments for the new format
The new firmware version naming allows a clear and easy comparison between the different versions and their implemented features (PCD type specific) and bug fixes. Questions like "why is the alarming functionality of the PCD3 Web Server implemented in firmware version \$31 but not in version 031?" - They both do have the same number... should be past (however, if you're interested in the answer, please refer to FAQ100176)

Format description
The new firmware version name does consist of a major version, a branch version and a minor version separated by a dot (.). Note that the prefix characters "0", "1" or "2" are no longer used in this notation. a.bb.cc

- cc is the minor version**
With each version the minor version is incremented by one. If bb changes, the minor version starts at 0.
- bb is the branch version**
• even indicates a maintenance or release version
• odd indicates a pilot version (with new functions)
Changes if a new release branch is generated!
- a is the major version**
Starts with 1, changes if major changes are released or if \$b overflows

Concerned systems
The new firmware version format will be applied to the systems based on Saia-NT firmware (Classic and xT). These are:

- PCD3.Mxxxx
- PCD3.M48x
- PCD3.M5xxx
- PCD7.D4xx (MS Panels)

While the firmware names for the MS Panels do already have this format, it will be introduced on the PCD Classic systems with the next firmware version after 036 for PCD3 and PCD2.M480.

News about PC software

Package	Version	What's new
Controls Suite (including PG5)	SP 1.4.120	<ul style="list-style-type: none"> - Web-Editor Version 5.11.06, first official version with trend and alarm functions - S-Web-Connect 2.0.5.0, has been completely revised - FBoxes for PCDx.W525 - Support of the new format for OS NT firmware versions - HMI Editor 1.4.210, supports Cyrillic characters when using PCD7.D23x terminals from firmware version 040 <p>A fully functional demo version that will work for 90 days is available under www.sbc-support.ch. For an update, please contact your Saia® affiliate</p>

News about firmware

Product	Version	What's new
PCD3.Mxxxx / PCD2.M480	V03C	<ul style="list-style-type: none"> - Support for the alarm function of the Web-Editor - Support for 2-fold serial modules PCD3.F2xx (PCD3 only)

New documents since Controls News 9



P+P26/376



P+P26/476



P+P26/479



P+P26/446



P+P26/472



P+P26/432



P+P26/454



P+P26/436



P+P26/457



P+P26/216

Name	Doc type	Document No.	Status
SBC Profile (Brief Portrait)	Flyer	P+P26/376	new
Promotional Flyer	Flyer	P+P26/476	new
OEM Flyer	Flyer	P+P26/477	new
HMI Concept	Flyer	P+P26/463	new
SI Flyer for System Integrators	Flyer	P+P26/478	new
SI Flyer for Investors	Flyer	P+P26/479	new
Data Management	Flyer	P+P26/458	new
Ethernet Switch	Flyer	P+P26/472	new
PCD2.M5xxx	Flyer	P+P26/446	new
EIB / KNX Driver	Flyer	P+P26/448	new
HEAVAC Web templates	Flyer	P+P26/455	new
MP-Bus Interface	Flyer	P+P26/481	new
DDC-Suite	Flyer	P+P26/480	new
PCD3 Series	Flyer	P+P26/384	revised
S-HMI Overview	System Overview	P+P26/432	revised
DDC Compact	Technical Information	P+P26/345	revised
Single phase AC Counter	Technical Information	P+P26/433	revised
3-Phase Counter	Technical Information	P+P26/436	revised
PCD7.D290	Technical Information	P+P26/454	new
PCD7.H104S S-Bus Interface	Technical Information	P+P26/457	new
PCD3.M3120	Data Sheet	P+P26/447	new
PCD3.M634x - CAN for PCD3	Data Sheet	P+P26/449	new
Profibus Master CPU PCD3.M6540	Data Sheet	P+P26/450	new
PCD3M5340 - RS 422	Data Sheet	P+P26/474	new
PCD2/3.W525	Data Sheet	P+P26/475	new
PCD3 Compact	Data Sheet	P+P26/473	new
System Catalogue	Catalogue	P+P26/215	revised
Control Components Catalogue	Catalogue	P+P26/216	new
PCD2.M220 PC104	Manual	26-759	revised
PCD3	Manual	26-789	revised
Web-Server Classic	Manual	26-790	revised
S-Web-Connect	Manual	26-800	revised
PCD7.D290	Manual	26-841	revised
P.DDCL701	Manual	26-846	revised
BACnet	Manual	26-849	new
PCD7.D4xx	Manual	26-851	new
PCD2.W525 & PCD3.W525	Manual	26-853	new
PCD7.L600 Room Controller	Manual	26-854	new
PCS1	Manual	26-781	new
File System	Manual	26-855	new

Practical test: Accessing Saia® PCD controllers with CGI

The CGI interface - which simplifies the accessing of PLC data from any PC/Windows® system – has already been explained in the last issue of ControlsNews*. Now let us provide the proof: with a simple Visual-Basic program, you yourself can access a PCD controller by internet. This demo program is ready for downloading from the Saia-Burgess Controls website in two forms: as an executable file and as a Visual-Basic project (source) (www.start-controls.com/vb-samples).

*) CN9: Windows®....
Pages 8 and 9 → check!



Windows® already provides all you need to communicate with PCD controllers, even without special drivers or OPC servers. The .NET standard classes WebRequest and WebResponse allow web contents to be downloaded from internet. Only four instructions are required in Visual-Basic .NET:

```

` Define objects for web access
Dim wReq As WebRequest
Dim wResp As WebResponse

` Access web page
wReq = WebRequest.Create("http://192.168.0.230/demo.html")

` Read response
wResp = wReq.GetResponse ()

```

CGI instructions follow exactly the same principle. Instead of a URL to download a web page, a URL is simply given with a CGI command. A summary of the main CGI commands for PCD xx7 controllers will be found in the info box here. Of

course, the CGI interface also exists on PG5 programmable PCD controllers; you just have to adjust the syntax for controller data.

Practice: Test it yourself !

To let you form your own impression of how easy it is to work with CGI commands and use them within .NET programs, we have drawn up a simple Visual-Basic program for demonstration purposes. You can download it from the Saia-Burgess Controls web site. Two versions are available for downloading: the packed file «VB_WebDemo_CN10_project.zip» contains the entire Visual-Basic project, which you can open and modify with Microsoft® Visual-Studio 2005. For those of you who would just like to see for yourselves how web-based operation works with a .net application, a ready translated application is included in the packed file «VB_WebDemo_CN10_binary.zip». The demo-program «VB_WebDemo_CN10.exe» will run on any Windows® computer with the .NET framework installed. If this framework is not installed, it can be downloaded free from Microsoft® and installed. Execution of the program also requires an installed, active internet connection.

In case you do not have a PCD controller at hand just now, we have made a STEP®7-compatible controller of the type

PCD5.M5547 available via internet (physically, the PLC is located in Murten/Switzerland). You can call this controller under <http://cgi-demo.saia-sps.dyndns.org>. The demo program that will access this controller is divided into three tabs. On the first tab, the marker word 100 can be incremented by 1 with a button. The actual value of marker word 100 is displayed below it. The second tab shows the default start page of the controller's web server. The third tab establishes a connection with the website of Saia-Burgess Controls Ltd. For the sake of clarity, we have kept the Visual-Basic program as simple as possible and deliberately left out comprehensive error handling. Therefore, improper use – e.g. in the absence of an internet connection – may make the program respond slowly, or not at all. If the worst happens, just close the program with the task manager. Finally, do not be sur-



Increment marker word 100 with Visual-Basic program

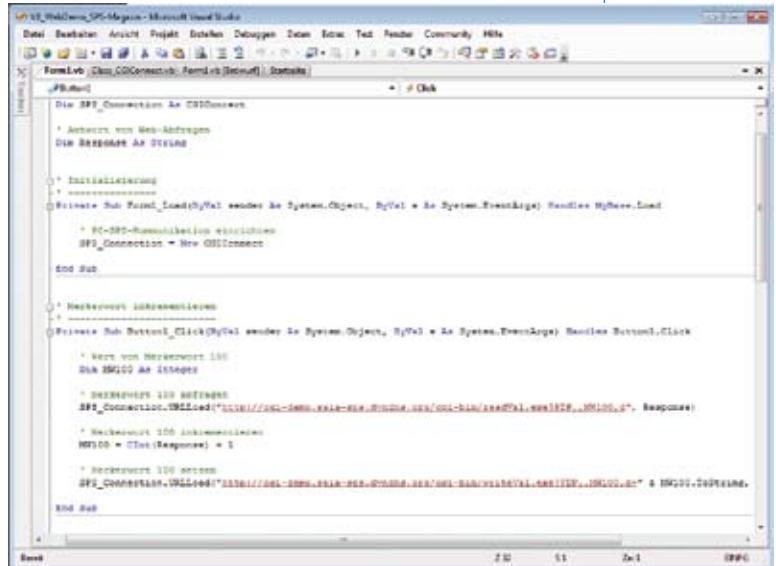

Access PLC data with Visual-Basic, easy to program with CGI commands in Microsoft® Visual-Studio

prised if marker word 100 changes with no intervention from you – this just means that another interested reader is busy trying out this new, fascinating technology. ■

CGI-Syntax: Polling PLC data with a standard browser

Saia-Burgess PCD controllers offer a CGI interface that can be used to access PLC data with standard browsers and Java/.net standard classes. To do this, CGI commands are sent to the controller in the form of a URL.

Read data from PLC:

http://<IP_DNS>/cgi-bin/readVal.exe?PDP.,<SPS-Daten>,<Format>

Write data to PLC:

http://<IP_DNS>/cgi-bin/writeVal.exe?PDP.,<SPS-Daten>,<Format>+<Wert>

Syntax:

- <IP_DNS> ⇨ IP or DNS name of controller;
e.g. "192.168.100.33" or "cgi-demo.saia-sps.dyndns.org"
- <PLC_data> ⇨ Data (type and address) of controller to be accessed;
(xx7)
 - I, IB, IW ⇨ Input, e.g. I100.2, IB100, IW100
 - Q, QB, QW ⇨ Output, e.g. Q100.2, QB100, QW100
 - M, MB, MW ⇨ Marker, e.g. M100.2, MB100, MW100
 - DB(X/B/W) ⇨ Data block, e.g. DB100.DBX10.5,
DB100.DBB10, DB100.DBW10
- <Format> ⇨ Format;
d/b/x/s ⇨ decimal/binary/hexadecimal/string
- <Value> ⇨ Value to be written to the PLC.

DIVISION INFO AND REFERENCE APPLICATION

Reorganization of Saia-Burgess Controls – the next step in company development

In recent years, Saia-Burgess Controls has developed well and growth has been equally strong. We intend to safeguard this positive trend for the future and are therefore concentrating on an organic growth phase: growth through more satisfied, successful customers.

To provide existing customers with a fuller service and speed up the acquisition of new customers, we have completely changed our organization with effect from 1.4.2007.

We have transformed the organization's functional structure (with one department for purchasing, one for logistics, one for assembly and one for development) into a business unit structure comprising the following business units: Controllers & Interfaces, HMIs and Control Components. Each BU is self-sufficient and can therefore respond most speedily to the challenges and opportunities of the market.

In Sales and Support, we have transformed an orientation towards markets into a logical orientation towards types of customers. ■

Corporate Sales

Business Unit

CC



Business Unit

CI



Business Unit

HMI

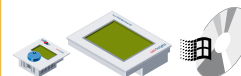

Central Production Services

Exhibitions/Trade fairs



27. – 29. November 2007
SPS/IPC/DRIVES, Nürnberg,
Germany (DE)

22. – 26. January 2008
HILSA, Basle, Switzerland (CH)

5. – 8. February 2008
INTERCLIMA,
Porte de Versailles, Paris,
France (FR)

11. – 15. February 2008
VSK, Utrecht, Netherland (NL)

19. – 22. February 2008
Magyar Regula, Hungary (HU)

19. – 20. March 2008
IAS, Nieuwegein,
Netherland (NL)

1. – 4. April 2008
Nordbygg, Stockholm,
Schweden (SE)

1. – 4. April 2008
Automaticon 2008, Warsaw,
Poland (PL)

6. – 11. April 2008
Light & Building, Frankfurt,
Germany (DE)

21. – 25. April 2008
Hannover Messe, Hannover,
Germany (DE)

20. – 23. May 2008
Het Instrument, Utrecht
Netherland (NL)

26. – 29. May 2008
Eliaden 2008, Lillestrøm,
Norway (NO)

27. – 29. May 2008
Wod-Kan 2008, Bydgoszcz,
Poland (PL)

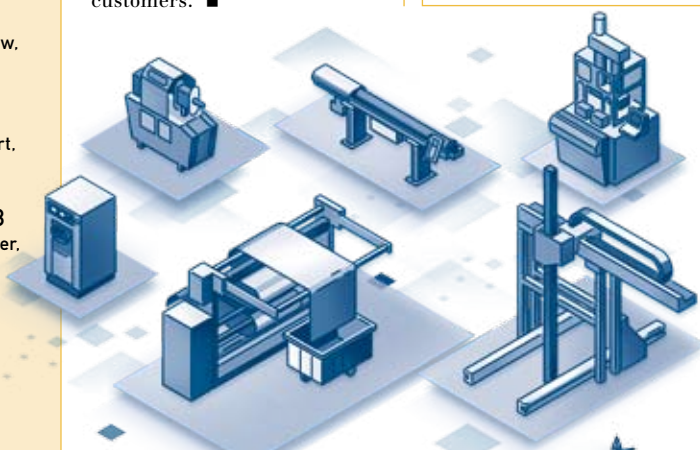

Rolf Müller
in charge of developing business
with OEM customers

Machine Control – OEM



Infrastructure-Automation

Joachim Krusch
in charge of developing business
with system integrators



High investment volume for Controls – a basis for further growth

Since 2006, much has been invested in new machines and equipment. This has enabled us, for example, to introduce into our production all the usual commercial test procedures for modern microelectronics. This has accelerated the market launch of new products and reduced residual risk for existing products.

Regarding weld technology, in spring 2007 we purchased a wave soldering machine that has been specially constructed for the leadless soldering process.

The most recent major investment was commissioned in September. We have expanded our SMD lines with three new Siplace machines from the latest generation. This provides more production capacity, allows the reduction of costly, fault-prone manual assembly, and increases process security by integral, digital image processing. An investment of many millions that will pay dividends for everyone.



New wave soldering machine for the leadless soldering process



Production of Saia-Burgess Controls with three new Siplace machines

Investments in better customer service

In July, after a long period of removals and rebuilding, the new logistics centre for Controls sales organization was put into service. It allows larger stocks of finished products to be kept and makes us even better able to supply anywhere in the world directly and speedily, should any part not be available locally.

Investments for speed and process competence

Currently, another major investment amounting to approx. EUR 1 million is underway and concerns the infrastructure of Controls production. We are building new, dust-free, air-conditioned rooms for HMI production and are consolidating the entire production of Saia®PCD products with Development, Sales and Logistics. In contrast, the Control Components business unit will be consolidated in Factory II at our Murten location. This will result in more compact, better integrated business units. ■



All Saia®PCD development, production and logistics are now not only united in one location, but even under one roof.

Imprint

Controls News is published twice yearly in five language versions: German, French, English, Italian, Dutch.

Publisher

Saia-Burgess Controls Ltd, Bahnhofstrasse 18, CH-3280 Murten
Tel.: +41 26 672 71 11 | Fax: +41 26 672 74 99
www.start-controls.com | pcd@saia-burgess.com

Responsible for

the English edition: Patrick Marti, Saia-Burgess Controls Ltd

Editorial team

Jürgen Lauber, Patrick Marti, Sandra Hofer, Michael Gehlhaar, Jürg Hurni, Urs Jäggi, Kostantinos Kafandaris, Joachim Krusch, Rolf Müller, Thierry Rebut, David Rieder, Robert Scheiwiller, Peter Steib; Saia-Burgess Controls Ltd

Conception, design and production

Sandra Hofer, Saia-Burgess Controls Ltd

Lötschberg Basic Tunnel includes much Saia®PCD technology

Impressive figures for rail engineering and infrastructure

- Tunnel length: 34.6 km
- Total material excavated: 16 million tons (equal to 400 000 40-ton trucks)
- Length of track systems: 57 km
- Total length of power cable: 1390 km
- Electric control boxes: 2400
- Fire detectors: 3200
- Lights: 2500
- Video cameras: 133
- Stainless steel containers: 136
- Saia®PCD2 devices: 630
- Saia®PCD1 devices: 20
- Saia®PCD3.RIO devices: 1470
- Saia®PCD7.D231 devices: 430
- Total Saia®I/Os: 30 000
- Overall costs: CHF 4.2 billion
- Saia® share: CHF 1.6 million

A promise has been kept that was made both to the Swiss nation and to Europe: the construction project of the century has finished on time and on budget. An inauguration ceremony took place on 15.6.2007. From December 2007, 42 transalpine high speed trains a day will travel through the 35 km long tunnel at speeds of up to 250 km/h, as well as 80 goods trains. Switzerland will become an important routing centre for the future network of fast rail and goods traffic. This tunnel is the result of detailed political discussions, farsighted decisions, and many technical masterstrokes.

Several hundred Saia®PCD controllers are in use to equip the technical infrastructure.

From political process to tunnel construction

Switzerland did not want to become a road corridor for 40-ton juggernauts. Instead, a series of national referenda pointed decision makers towards the expansion of rail traffic:

- 1992: Referendum on Alpine crossing resolution with the EU. Agreement with the EU on Alpine crossing.
- 1993: Referendum on the new Alpine crossings. CHF 30 billion credit granted for rail expansion over the following 20 years
- 1993: Establishment of «BLS Alptransit» and start of exploratory tunnelling
- 1994: Referendum on the Alpine initiative (further expansion of transalpine roads blocked to protect the Alps)
- 2000: Commencement of construction works for the Basic Tunnel
- 2005: Completion of cutting works for the Basic Tunnel
- 2007: Inauguration ceremony and start of operations



Technical masterstrokes – with Saia®PCD controllers

Containers

Inside the tunnel there are a total of eight control centres that incorporate 136 containers for rail technology. This includes systems for the 50Hz power supply, equipment for radio, control and safety, and installations for the no-break power supply. Climate conditions in the tunnel, with an ambient temperature of 35°C and relative humidity of around 80%, call for reliable air conditioning. Several hundred Saia®PCD2 controllers are used for the containers' redundant system of air conditioning, some of which are PCD2.M480 devices with duplicate Ethernet interfaces.

Aerial contact line

In both galleries of the tunnel, the aerial contact line has been designed for a current capacity of 2000 amps. This means that six locomotives in either direction can be supplied with power. Because of high air resistance when travelling through the tunnel, a high speed train at 250 km/h will use about the same amount of energy as a normal train on a mountain stretch – but will be approx. 5 x faster.

Control boxes in crossways

Every 335 m, the single-track tunnel galleries are connected by crossways: 104 in total. In these crossways will be found around 1500 air-conditioned control boxes containing equipment for the power supply, emergency lighting, fire alarms, data transmission and radio. Here several hundred Saia®PCD2 controllers ensure operational security and integrate the individual, self-contained systems into a complete tunnel infrastructure system. Systems may also be controlled on-site by means of the simple but robust PCD7.D231 control displays.

ETCS and mobile telephone system

Trains are controlled by the European Train Control System (ETCS), a digital radio system. There are no conventional signals in the tunnel. ETCS is based on the same GSM technology that is used by mobile phones. A primary optical fibre system guarantees fast data connections both for rail control and for the telephone calls of train passengers. Here Saia®PCD2 controllers ensure smooth data transmission from remote radio installations to the tunnel's radio control centres.

From December 2007, the journey time through Switzerland will be less than 2 hours. Europe will have come closer together – due in part also to Saia-Burgess Controls Ltd, the innovative controls producer in the heart of Europe. ■

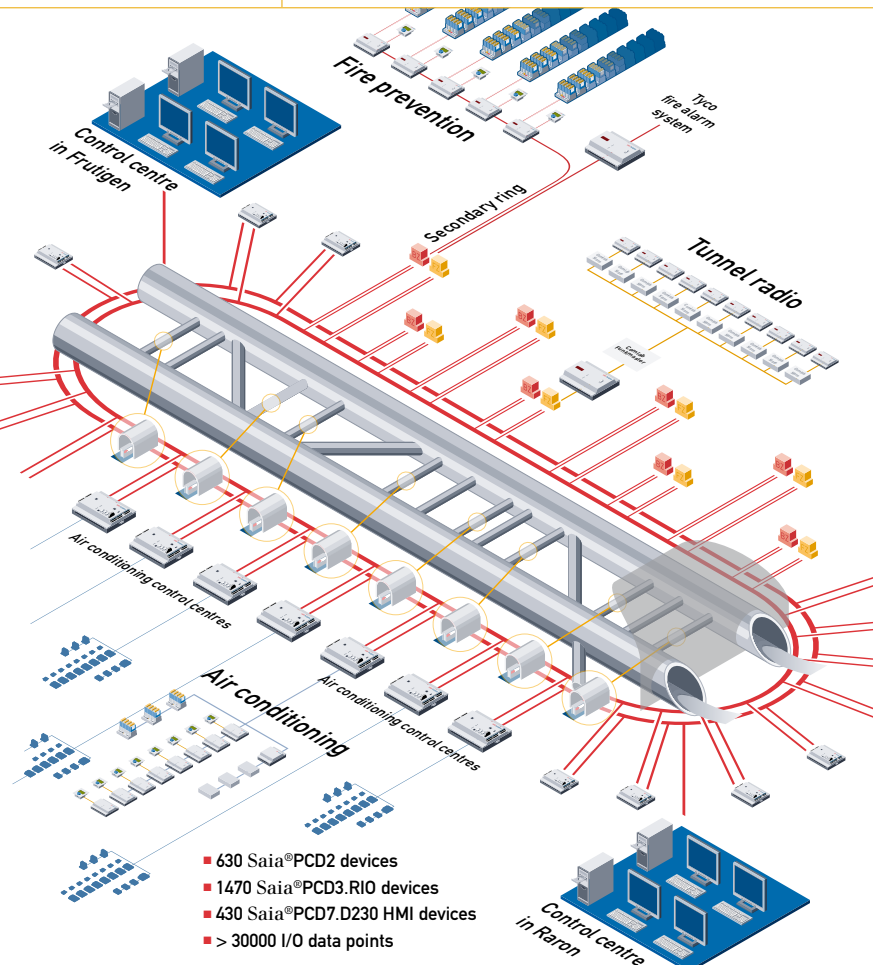

Building Management of new CONTINENTE Hypermarket in Ovar, Portugal

The highly versatile and powerful communication capabilities of Saia®PCD3 controllers were key to reduce the control hardware and secure all the necessary communication to all the equipment installed for the energy, the ventilation, lighting air conditioning units.

Project
Customer: SONAE, S.A.
Integrator: Infocontrol, Lda.,
www. Infocontrol.pt



Last April, the 20th and most recent CONTINENTE Hypermarket, opened its doors. Located within the Shopping Area Dolce Vita Ovar, this new CONTINENTE is well placed to deserve a population of 118'000 inhabitants in the North of Portugal.

The customers and the 160 people employed within the 5'000 m² of sales surface have all the comfort expected today in modern shopping centres. Intelligent lighting, comfortable air conditioning, ventilation of sensitive areas, production of hot water, energy monitoring and management are provided thank to a Saia®PCD3 network engineered and provided by Infocontrol.

In total, 4 Saia®PCD3.M5540 stations with 800 I/Os are connected to a Genesis32-Enterprise supervision. This controls networks take care of all automated actions: lighting, climate control of public areas and office areas, ventilation of labour areas (Bakery, Fish market, etc) and technical areas, hot water production, use of the heat produced by the industrial cold production, optimization of energy consumption, monitoring of electric network (values, status, etc.) and reporting of energy costs (electricity, water, gas).

All PCD3 are linked to the LAN via Ethernet, allowing high speed, multi-master data transmission and remote access to control and program all PCD3.

The Modbus communication is used on PCD3 to connect all energy analyzers to receive instantly all electrical values (Voltage, Current, Power, Frequency...), all Air Conditioning Units to receive and modify the operational settings (like temperature, humidity, pressure...), the emergency generator to receive online all electrical values, alarms and status.

The BACnet®-IP capability of PCD3.M5540 is used to manage and monitor all climate units in offices within the building management system. ■

Technical profile

4 stations PCD3.M5540
800 I/Os

Bus protocols:

- S-Bus over TCP/IP
- S-Bus over RS485
- ModBus RTU over RS485 and RS232
- ASCII over RS232
- BACnet®-IP

Supervision:

- ICONICS Genesis32-Enterprise



Project «Ahus» – Controlling operation rooms with Saia®PCD3 !

The «Best in Class» communication capabilities of Saia®PCD3 combined with the technical skills in software design from Malthe Winje helped to massively simplify the system design, increase the performances and reduce costs.

AHUS, the Akershus University Hospital, 15 km north of Oslo is one of the largest European hospitals deserving a population of 340'000 inhabitants. With over 900 Mio Euro of investment for a total floor surface of 137'000 m², AHUS will be in 2008 the most modern European health center.

An important part of the project was the conception of new systems to control and supervise the HVAC functions and medical gas detection system in 30 medical operating rooms with extreme demands of security and reliability.

For this demanding tasks, Gunnar Karlsen, a major player in Scandinavian building automation solutions choose to rely on Saia®PCD. 45 stations PCD3.M3350 with Modbus TCP communicate with the top-line SCADA system

from Honeywell. And 35 touch screen panels with eXP ensures a precise and comfortable control and monitoring of parameters in every operation room.

The «Best in Class» communication capabilities of Saia®PCD3 combined with the technical skills in software design from Malthe Winje helped to massively simplify the system design, increase the performances and reduce costs.

Gunnar Karlsen, founded in Norway in 1964, is a leading building automation solution provider active in new and existing building as well as in off-shore installations. With 1000 employees in 50 offices throughout Scandinavia, Gunnar Karlsen achieves a turnover of 200 mio Euro and keep going on growing by capitalizing on high tech solutions and strong local presence.

Malthe Winje (www.mwa.no), the representative of Saia-Burgess Controls in Scandinavia, could provide support, consultancy and programming assistance to Gunnar Karlsen to solve this automation challenge in extremely short time. ■



Screen shot from the 15" touch panel: Programmed in C# - .NET based using MS Visual Studio with the SComm.dll library.

WEG Revamps Cold Reversing Mill in Brazil With Very Critical Thickness Tolerance

Saia®PCD2.M480 controls precisely thickness of steel strips speeding at 9 m/s. Armco is a steel company, located in São Paulo, that has a complete line of coated and re-rolled steel coils, covering a wide range in the industrial segments. The cold reversing mill revamped in Armco has 500m/min maximum speed, with strip width from 210 up to 515 mm and strip thickness varying from 0,10 - 6,30 mm. The main objective was to improve the thickness quality.



WEG provided a complete system automation comprising two Saia®PCD2.M480 CPUs, remote I/Os, Profibus-DP, Ethernet, Scada and integration to the managing system, via Web.

A WEG special Automatic Gauge Control strategy was implemented in the Saia®PCD2.M480 improving the quality of thickness tolerance to $\pm 0,003$ mm. This very good performance reduced the thickness rejection around 60%.

Due to the pre-established recipes the products started to be produced with a better repeatability, improving the general quality. The implementation of alarms, automatic diagnoses and special routines in PCD2 like the mill automatic slow down (ASD) increased the productivity in more than 20%.

The revamping also involved five digital DC drives from 1000 A up to 1700 A in substitution to the Ward-Leonard drive system and a Motor Control Center for the peripheral equipments.

WEG is the largest Latin American electric motors,

drives (inverters and soft-starters) and switchboards manufacturer and is present in over 100 countries in the five continents. Its products range includes also generators, electrical components, industrial automation products, power and distribution transformers, liquid and powder paints (www.weg.net). ■



VIP Golf Event in Lisbon



Last May, Infocontrol invited their Top 20 customers and users of Saia®PCD to a VIP Golf Event in Quinta da Beloura near Lisbon.

This was an opportunity for Infocontrol and Saia-Burgess to present to decision makers the latest evolution of the Saia®PCD portfolio.

A special accent was put on Web and IT combined with Saia®PCD controllers : a unique combination of technologies allowing system integrators and system owners within a control network unprecedented access and use of data at lowest costs. The new range of Saia®Web HMI and the extended memory management possibilities illustrated adequately how to use these decisive and competitive new features everywhere. Our guests not only appreciated a direct access to key information to increase their competitiveness, but also to be challenged and have fun in golfing together. ■

Czech Republic : SBsys has new office space

After one year of activity SBsys, reseller of Saia-Burgess Controls products in Czech Republic, moved into a new office closer to the city Center and better accessible for partners and customers. The new office offers enough space for the planned company development, especially for building up a training and demonstration centre. The new meeting and training rooms offers good opportunities for all customers to discuss projects and train their technical staff. ■



www.sbsys.cz for contact and information

New distribution partner in Greece

GigaTech SA is the new distribution partner for Saia®PCD in Greece. Located in Anixi, near Athens, the Gigatech team is going to take care of PCD customers in industrial and infrastructure automation applications. www.gigatech.gr ■

Saia-Burgess Controls Ltd

Bahnhofstrasse 18 | CH-3280 Murten | Switzerland

T +41 26 672 71 11 | F +41 26 672 74 99

www.start-controls.com | pcd@saia-burgess.com